

# Instruction Manual Spare Part Lists Electric Diagram

## MORSØ Mitring Machine EFG Model E Future Green



2020.03.23



# DANLIST

PRECISION CUTTING & DOWEL DRILLING

Dan-List A/S  
Haraldsvej 21 - DK-8960 Randers - Denmark  
Phone: +45 8643 5155 - Fax: +45 8643 5100  
E-mail: [danlist@danlist.dk](mailto:danlist@danlist.dk)  
[www.danlist.dk](http://www.danlist.dk) - [www.danlistvideos.com](http://www.danlistvideos.com)

# EEC-Certificate of Conformity

**We hereby confirm that this machine is constructed according to EEC-machine directive 89/392/EWG, last modified by EEC directive 93/98/EWG.**

(This statement is not valid if an alteration not approved by us is made on the machine/equipment, or if the machine is not used as laid down in the instructions)



Dan-List A/S  
Haraldsvej 21 - DK-8960 Randers - Denmark  
Phone: +45 8643 5155 - Fax: +45 8643 5100  
E-mail: danlist@danlist.dk  
www.danlist.dk - www.danlistvideos.com

**Machine Description:** MORSØ Mitring Machine

**Type:** E Future Green

**Year of Production:** 2020

**Machine No.:** \_\_\_\_\_

Further used standards, standard drafts, and standard directives

- Harmonized standards: resp. EN 292, EN 294, EN 349, EN 418
- EEC - EMV - Directives 89 / 336 EWG
- EEC - Low-Tension Directives (73/23/EWG)
- national technical specifications especially the till now determinative safety regulations in Denmark.

Place: Randers Name: Claus Pedersen

Date: \_\_\_\_\_ Signature: 

<b>Introduction</b>	page A-1	Adjustment of length of stroke of the knife block	page F-5
<b>Functional Description</b>			
General description	page B-1	Adjustment of end stop for conveying	page F-6
Machine description	page B-2	Adjustment of Inductive Tracer	page F-7
Description of the electric system	page B-3	Adjustment of number of cuts	page F-8
Description of cutting	page B-4	Adjustment of return stroke	page F-8
Adjustment before cutting	page B-4	<b>Rectifying Faults</b>	
<i>Automatic cutting</i>		Methods for Repair	page G-1
cycle for small mouldings	page B-4	<b>Safety</b>	
with smaller length of stroke	page B-4	Safety devices	page H-1
cycle for wide mouldings	page B-4	Regulations	page H-1
<b>Technical Data</b>	page C-1		
Dimensions of work pieces	page C-2	<b>Index of Spare Parts</b>	
<b>Mounting Instructions</b>		Index	Page S-00
General	page D-1	Basic Machine, complete	Page S-01
Mounting of table extension	page D-1	Waste Chute, complete	Page S-01-1
<b>Operating Instructions</b>		Table, complete	Page S-02
Operating devices	page E-1	Table	Page S-02-1
Before operating	page E-2	Knife Block, forwards/backwards	Page S-02-2
Degree adjustment of fences	page E-3	Knife Block Unit, complete	Page S-03
Exact adjustment of fences	page E-3	Knife Block Unit	Page S-03-1
Adjustment of length of moulding	page E-4	Knife Block, up/down	Page S-03-2
DeLuxe Scale - Second stop	page E-4-1	Rebate Support, complete, L	Page S-04
Adjustment of rebate supports - moulding clamps	page E-5	Rebate Support, complete, R	Page S-05
Working procedure	page E-6	Moulding Clamp, complete, L	Page S-06
After working procedure – Cleaning	page E-6	Moulding Clamp, complete, R	Page S-07
		Table Extension, complete	Page S-08
		<b>Electrics</b>	
<b>Service References</b>		Electric equipment	Page EL-01
Lubrication instructions	page F-1	Electric Equipment – Control	Page EL-01-1
Changing knives	page F-2	Electric Diagram	Page EL-01-2 - Page EL-01-13
Grinding of knives	page F-3		
Changing of spare parts	page F-4		

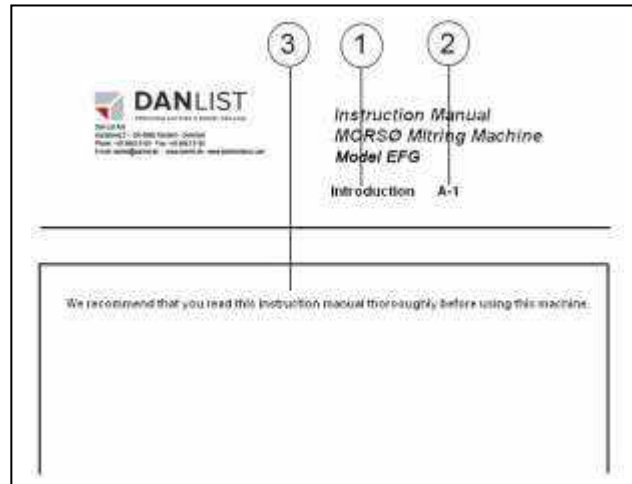

We recommend that you read this instruction manual thoroughly before using this machine.

Damage or faults on the machine caused by misuse or incorrect operation are not covered under our conditions of warranty.

**Use of the Instruction Manual:**

The reference system of this Instruction Manual described below will help you to quickly find the information you require (Picture A-1-1)

**(1) Subject Heading**

**(2) Page Index**

The letter (A) refers to the description of the section.

The number (1) refers to the page number of that section.

**(3) Text**

Description of the subject heading.

**Illustration**

A three-dimensional, numbered drawing of the text subject. The numbers in the text correspond to the numbers in the drawing.

### **General Description**

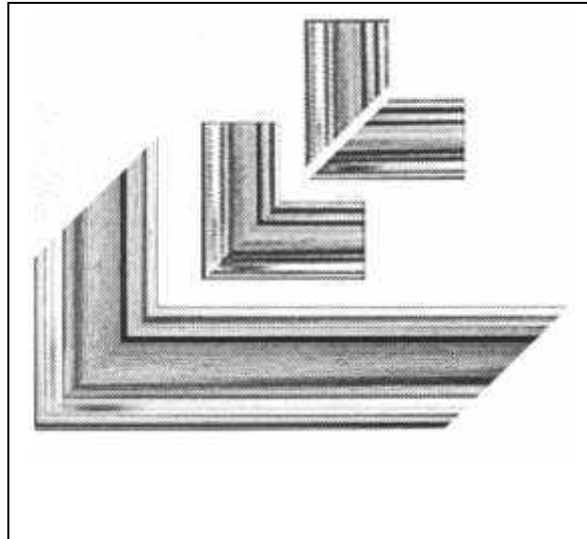

**MORSØ E Future Green** mitring machine is an invaluable help to make perfect 45° mitres in wooden mouldings for Picture Framers, and general wood working.

**MORSØ E Future Green** is fully automatic, electric. The operation is simple and effortless. Activating two pushbutton switches starts the cutting.

**MORSØ E Future Green** mitring machine is provided with sliding longitudinal stop, measuring scale, adjustable fences from 45° through to 90° on either side of the knife block, adjustable automatic rebate supports, and moulding clamps.

**MORSØ E Future Green** cuts double mitre at 45° and single mitre up to 90°.

**MORSØ E Future Green** allows you to achieve a perfectly smooth, clean, and accurate finish by nibbling the work piece in two cuts.

This is automatically done on the **MORSØ E Future Green** as a stop is built into the conveying thus causing that the knife block stops before the work piece is cut quite through. This stop simultaneously functions as a working cycle, because the knife block automatically goes to the last position to complete the cutting after which it returns to stop position.

**MORSØ E Future Green** therefore works continuously without the horizontal position of the knife block having to be adjusted manually.

The vertical movement of the knife block (length of stroke) is adjustable in three positions.

The pieces of moulding can be cut so accurately that they can be joined without any finishing.

**Machine Description**

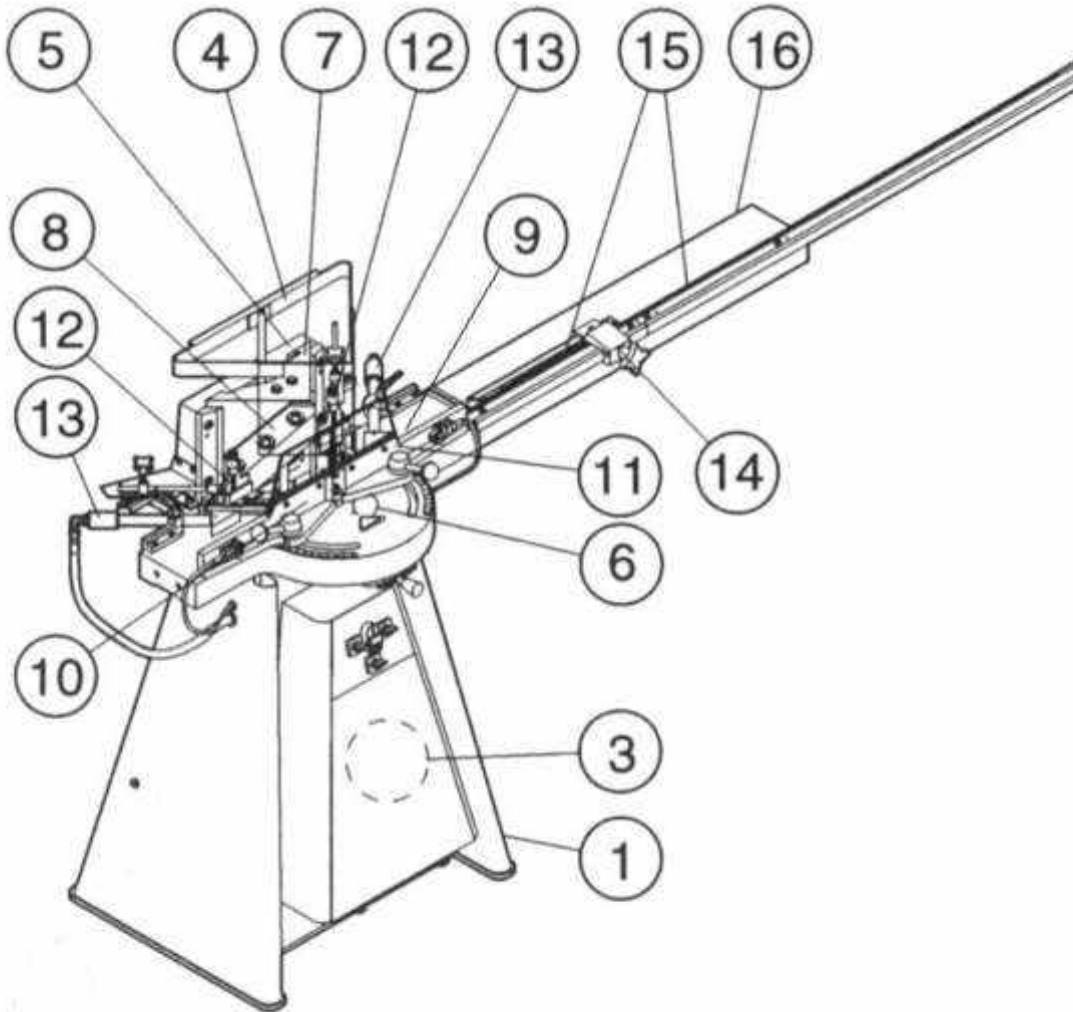

### ***Machine Description***

The **MORSØ E Future Green** is constructed as a compact machine with a sturdy frame (1), with built in electric equipment (3).

The cutting assembly (4) is situated at the top of the machine.

In the slide frame (5) fitted at the cross (6) the knife block (7) is moved up and down. The cross (6) runs in the guidings of the table.

The knives (8) fitted on the knife block cut the moulding.

Electric spindles draw the conveying and the knife block.

The moulding is placed on the table (9) against the fences (10) + (11) which has been adjusted to the required angle (usually 45°).

The rebate supports (12) are adjusted both to the width of the moulding and to the height of the rebate. The moulding clamps (13) are adjusted to the width of the moulding.

During the forward movement of the knife block the distance of the rebate supports according to the rebate is not changed.

The moulding clamps are fitted direct on the table.

The length of the finished moulding is adjusted by means of the stop block (14). The measurements are read from the scales (15) on the table extension (16).

The waste is falling via a slide on the floor or in a waste receiver. (The waste receiver is not supplied with the machine).

**Electric System**

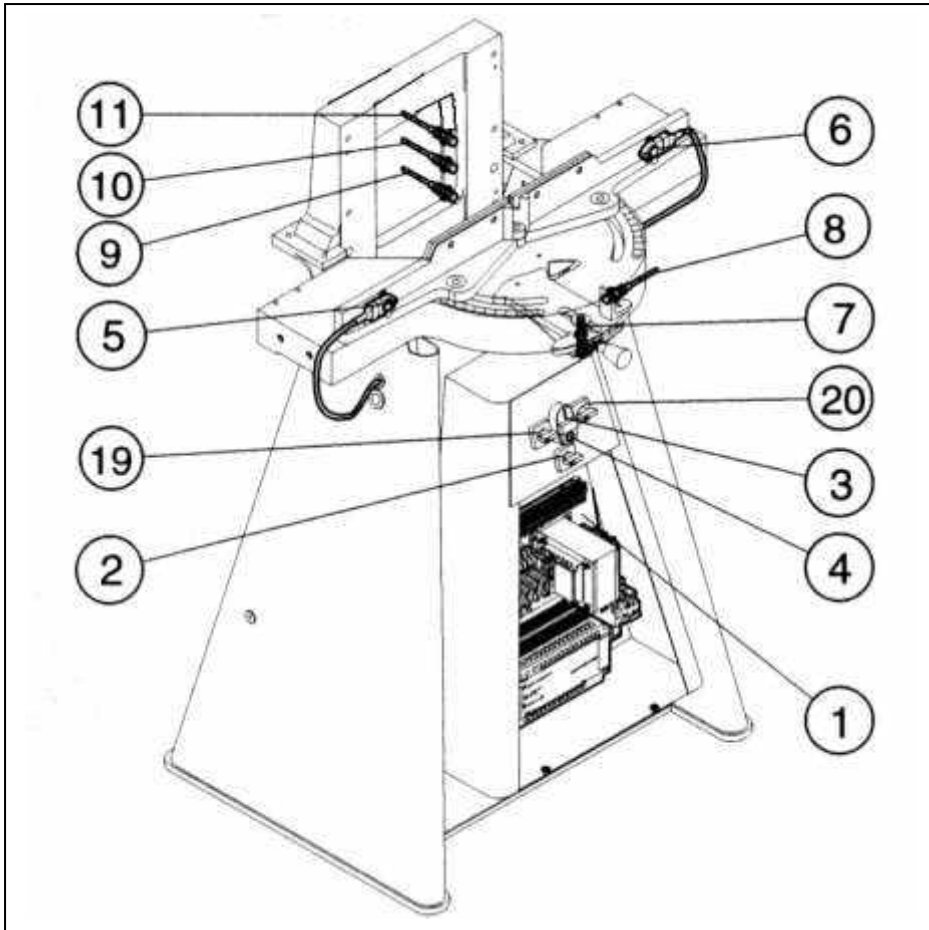

**B-3-1**

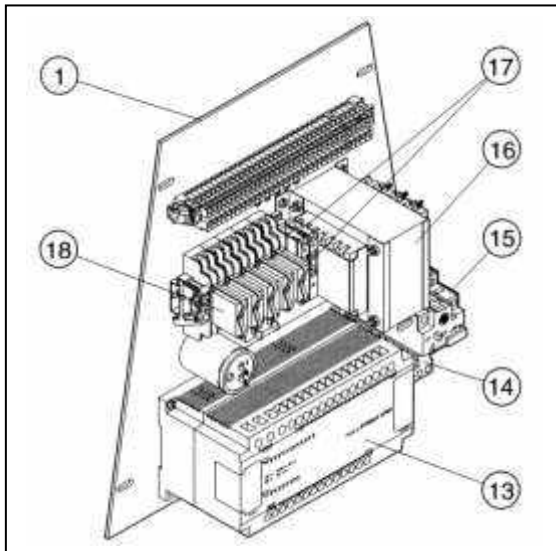

**B-3-2**



### ***Description of the Electric System***

All process sequences are controlled after a manual release of the control system (1).

With the pushbutton switches (3) + (4) the machine is switched on and off, respectively.

At the same time while the machine is switched on the motor starts via a relay (14) and the control (13) is ready for start.

The voltage for the specific functions is adapted in the transformer (16).

The motor is protected with a thermo relay (15) against overload.

Fine fuses (17) protect the control (13) and the working relays (18).

By adjusting the machine you have the possibility to disconnect specific conveying sequences of the process.

The current for the moulding clamps is controlled by the switch (2).

The length of stroke of the knife block is controlled by the switch (19).

The conveying of the slide frame unit is controlled by the switch (20).

Pushbutton switches (5) + (6):

Simultaneous activating: The cutting process is started.

Separate activating: Stepless horizontal movement of the knife block forwards and backwards, respectively.

All stop positions are limited by inductive tracers (7), (8), (9), (10), + (11).

**Description of Cutting**

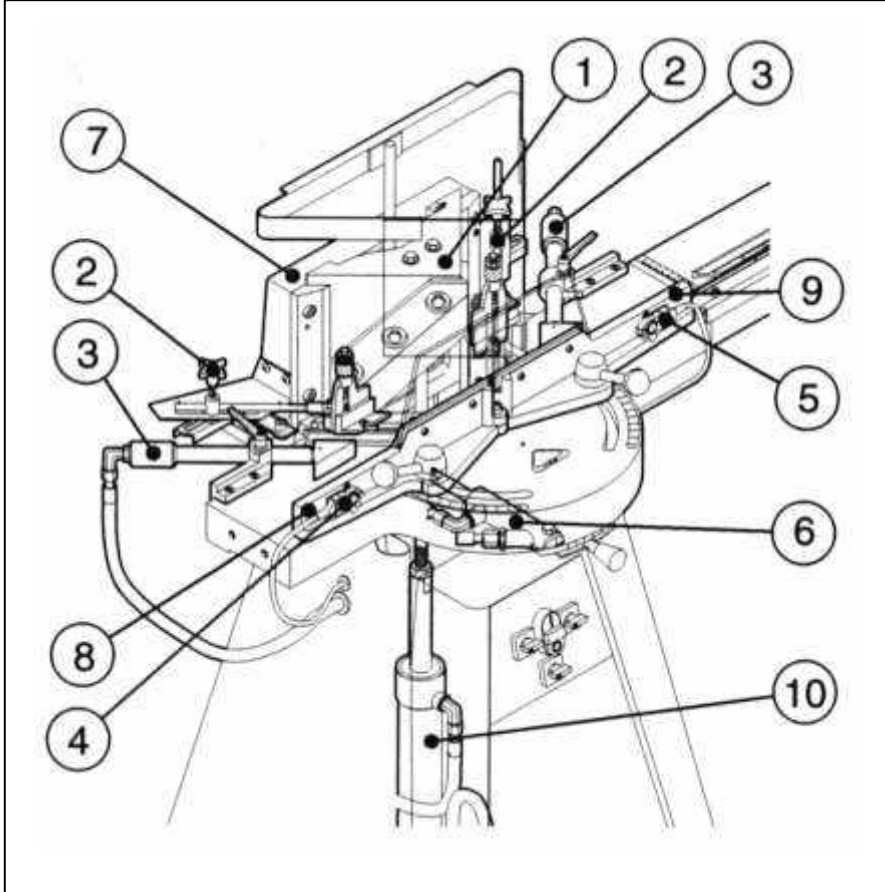

B-4-1

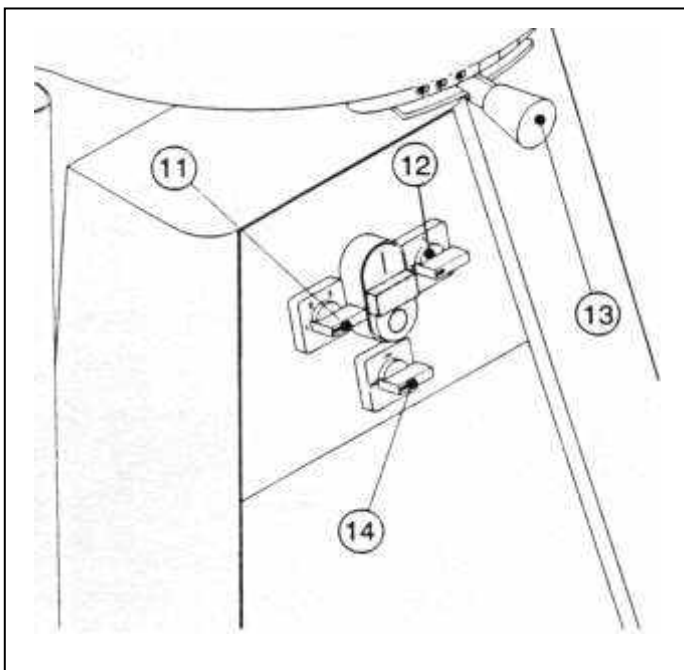

B-4-2

### **Description of cutting**

#### **Adjustments before cutting:**

The knife block (1) is in top position.

Working with a moulding with rebate the rebate supports (2) are adjusted to the height of the rebate and the width of the moulding. The moulding clamps (3) are adjusted manually to width of the moulding.

#### **A) Automatic cutting cycle for small mouldings (2 cuts)**

The knife block (1) is in front position.

Switching contact (12) is in position "0".

Switching contact (14) is in position "ON" (the moulding clamps (3) are activated).

By activating pushbutton switches (4) + (5) (two-hand-operation) the moulding clamps (3) press the moulding against the fences (8) + (9) and two cuts are made (the last cut is a so-called trim-cut).

Conveying spindle (6): horizontal movement (forward and backward) of the slide frame (7).

Spindle (10): Vertical movement (cutting function) of the knife block (1).

If you during cutting require bringing the knife block backwards and releasing the moulding clamps (3), the pushbutton switch (4) is activated separately. Be separate activating of push button (5) the knife block will go forward.

#### **B) Automatic cutting with smaller length of stroke of the knife block (1).**

The length of stroke can be adjusted in three fixed positions with switching contact (11) according to the height of the moulding. Thus you avoid a too long vertical movement of the knife block. The cutting cycle remains the same as at the automatic cutting.

#### **C) Automatic cutting cycle for wide mouldings**

Switching contact (12) is in position "1".

Switching contact (14) is in position "ON" (the moulding clamps (3) are activated).

Working with large mouldings that cannot be cut with the automatic cutting cycle of two cuts the following procedure is used:

The rear position of the knife block (1) is adjusted according to the width of the moulding stepless between 10 and 60 mm with the handle (13). With the switching contact (11) a suitable length of stroke is chosen.

Activate both pushbutton switches (4) + (5) for one cutting cycle without the moulding. After the cutting cycle the knife block (1) automatically goes to the adjusted rear position and the chosen length of stroke.

Put the moulding in the machine and activate pushbutton switches (4) + (5) and the cutting starts. After the first cut the knife block (1) automatically moves a suitable distance forward, then a new cut is automatically made, thus continuing, until the moulding is cut quite through. End cutting as in the automatic cycle for small mouldings.

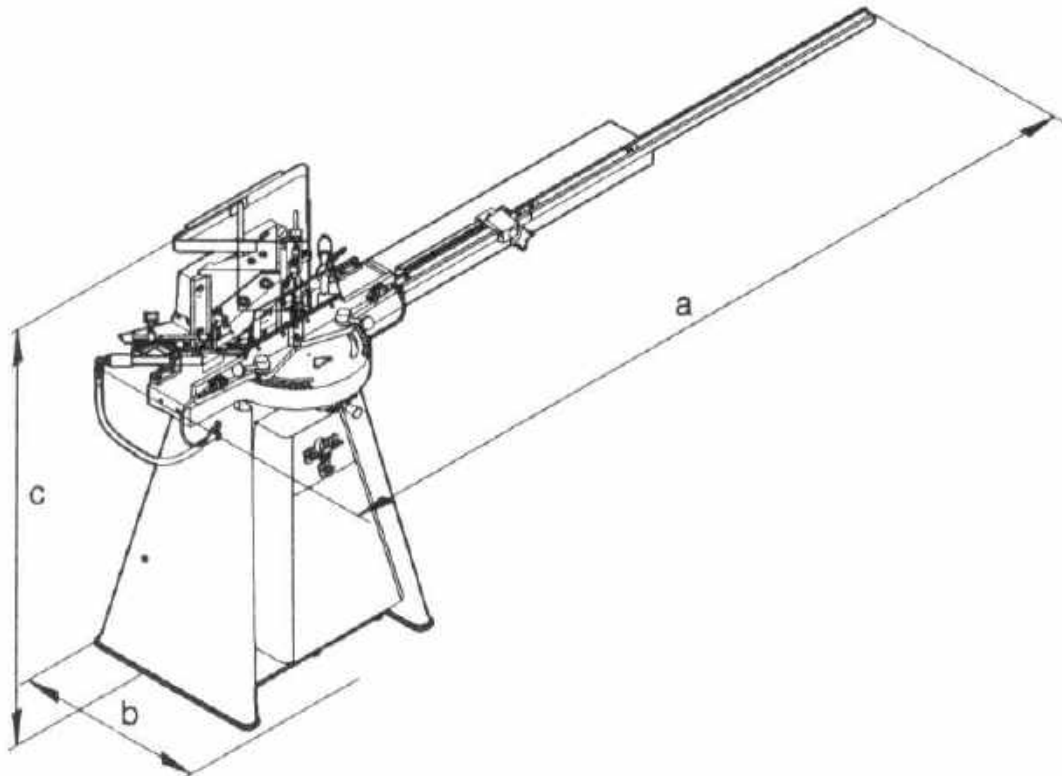

**Beware of the extremely sharp knives**

**Technical Data**

Technical Data			
<b>Machine Dimensions (max.)</b>		<b>Noise/Pollution</b>	
Length (a)	2,200 mm	Noise Level	below 70dBA
Width (b)	510 mm	Pollution	none/dustfree
Height (c)	1,150 mm	<b>Working Capacity</b>	
Weight	135 kg	Double Mitre	45°
<b>Placing Measures</b>		Single (left-right) up to	90°
Spaciousness to Wall min.	1,000 mm	Length of Moulding	
<b>Motor</b>	0.5 kW, 400 V	from 100 mm to max.	1,500 mm
Rpm	1360	Working Width (max.) *	100 mm
Type	SEW	Working Height (max.)*	180 mm
Gear	3.97	Measuring Scale up to	1,500 mm
		*please see diagram page C-2	



***In General***

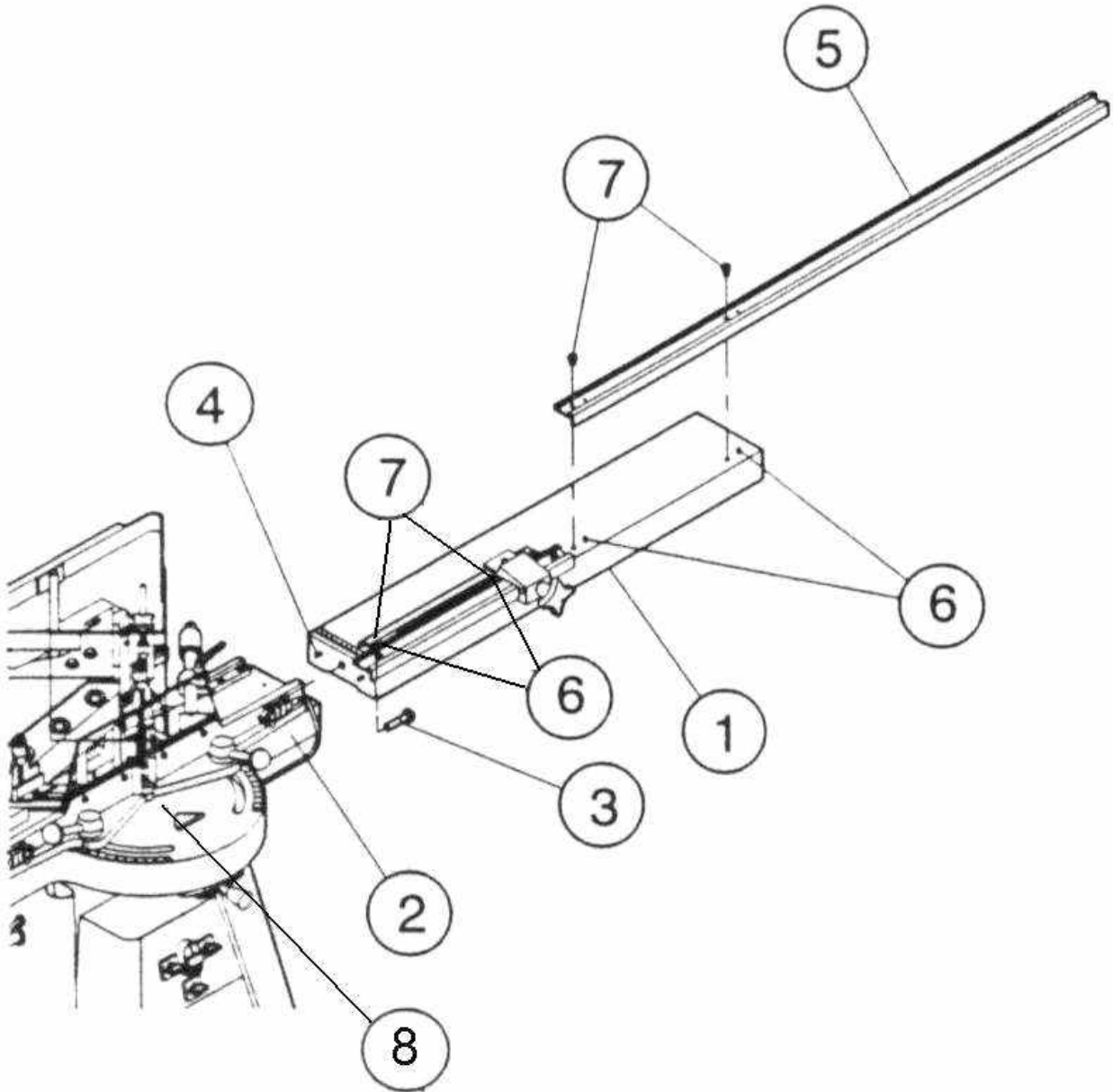

### ***In General***

The machine is delivered assembled ready for use except for the table extension (1) and divided beam (5) which is disassembled during transit. The machine comes complete with all standard equipment.

#### **NOTE**

After unpacking, and prior to initial operation, **REMOVE THE TRANSIT LOCKING PIN**, located in the centre of the machine table (8), and coloured black and yellow.

The distance between the location of the machine and any wall or obstruction should be as per C-1.

#### **Electric connection:**

We recommend electric connection **with** earth conductor. At three-phase electric connection the knife block must go into top position within a few seconds. If not, the machine is disconnected immediately, as the motor is running the wrong way. The phases must be changed.

#### **CAUTION**

Before each and every operation, ensure that ***all safety protection devices are in place and correctly fitted.***

#### ***Fitting of the Table Extension and Divided Beams***

Before fitting the table extension (1), both the table extension ends and the table end where they abut must be scrupulously cleaned, including the screw holes and pins. The tiniest amount of grit may prevent correct alignment.

After cleaning, the table extension (1) is offered up to the table so that the pins (4) align with the pin holes. A second pair of hands is extremely useful here. The bolt (3), which is supplied, can be inserted into its hole and tightened with a 19 mm socket wrench

The divided beam (5) can now be attached to the table extension (1), located with the pins (6) which are part of the table extension, and secured with the fixings provided (7).

*(Extra extension table and supporting leg is available as an accessory).*



**Beware of the extremely sharp knives**

**Operating Devices**

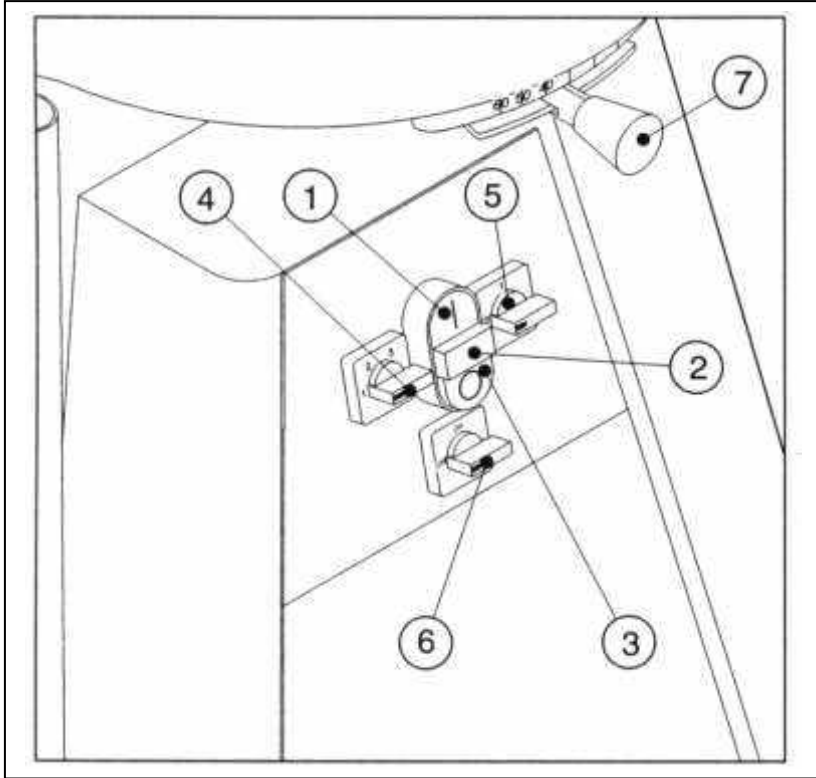

E-1

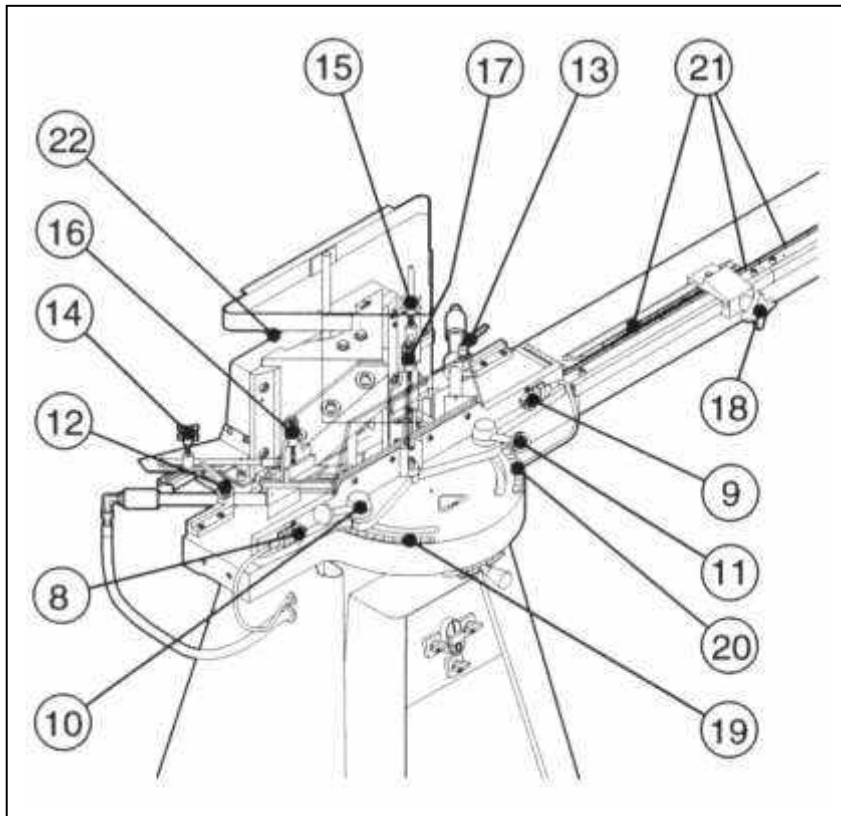

E-1-2



<b>Operating Devices</b>		
<b>Fig. E-1</b>	<b>Fig. E-1-2</b>	
<b>1 = Start Switch (green)</b> Switches the machine on	<b>8 = Pushbutton Switch</b> single-hand operation: switch (6) ON = moulding clamps are released conveying backwards two-hand operation = starting of cutting process	
<b>2 = Control Lamp</b> The machine is running		
<b>3 = Switch (red)</b> Switches the machine off		
<b>4 = Switch (3 steps)</b> Pre-selection of the length of stroke of the knife block Position 1 = shortest length of stroke Position 2 = second length of stroke Position 3 = full length of stroke	<b>9 = Pushbutton Switch</b> single-hand operation: switch (6) ON = moulding clamps are fastened conveying forward two-hand operation: = starting of cutting process	
<b>5 = Switch</b> Position 0 = the automatic conveying is inactive (manual adjustment without function). Position 1 = the automatic conveying is active. (the rear position of the slide frame is adjusted manually with handle (7))		
		<b>10 = Hand Lever - fastens the left fence</b>
		<b>11 = Hand Lever - fastens the right fence</b>
		<b>12 = Tightening Lever - fastens the left moulding clamp</b>
<b>6 = Switch</b> Position OFF: Moulding clamps disconnected. Position ON: Moulding clamps connected.	<b>13 = Tightening Lever - fastens the right moulding clamp</b>	
	<b>14 = Star Wheel - fastens the left rebate support</b>	
	<b>15 = Star Wheel - fastens the right rebate support</b>	
<b>7 = Handle</b> Manual adjustment of the conveying from 10 to 60 mm	<b>16 = Nut - height adjustment of left rebate support</b>	
	<b>17 = Nut - height adjustment of right rebate support</b>	
	<b>18 = Star Wheel – adjustment of stop beam</b>	
	<b>19 = Scale – degree adjustment of left fence</b>	
	<b>20 = Scale – degree adjustment of right fence</b>	
	<b>21 = Scale - length adjustment</b>	
	<b>22 = Hand Wheel - fastens the guard over the knife block</b>	



**Beware of the extremely sharp knives**

**Before Operating**

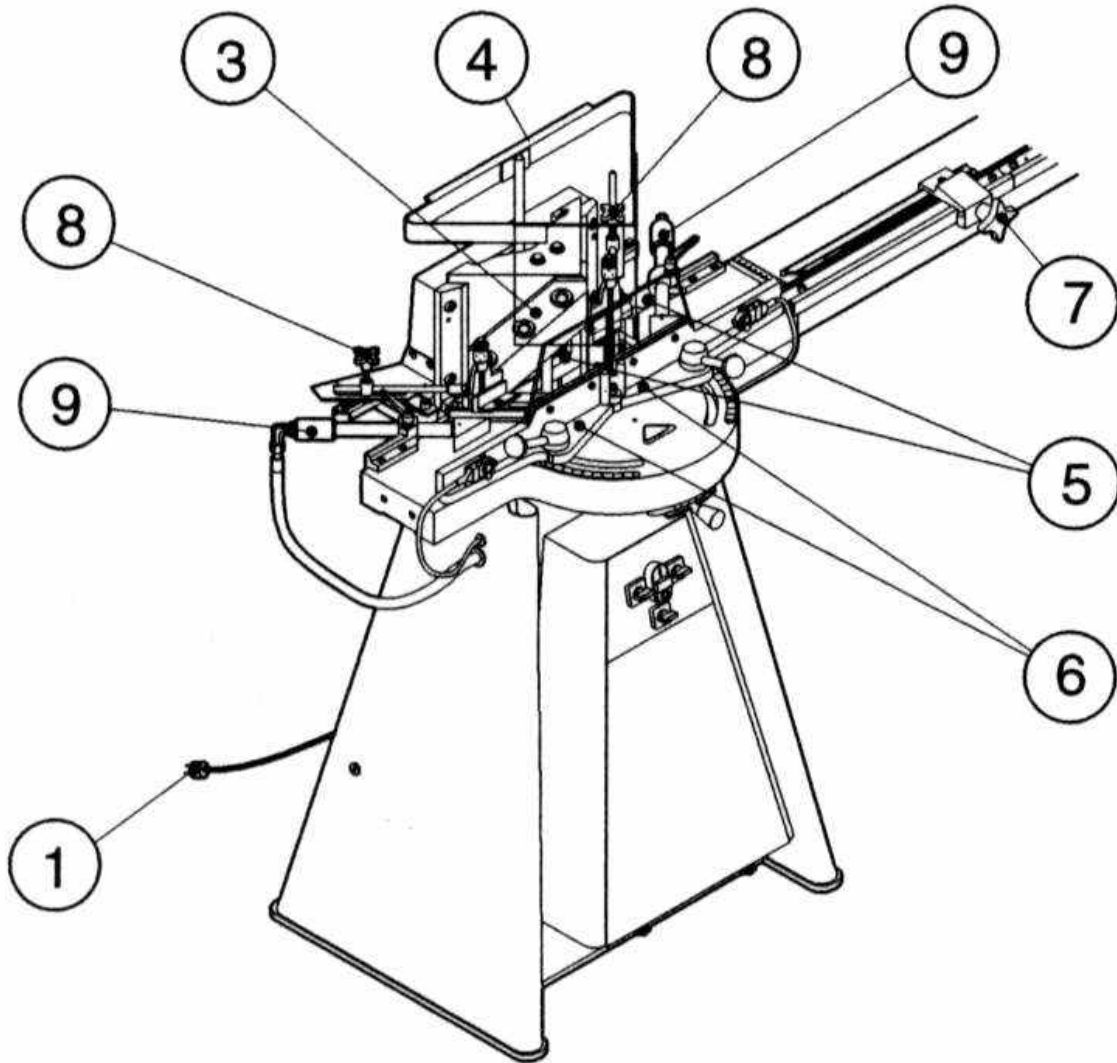

### ***Before Operating***

Before operating the machine the following must be checked and adjusted:

#### **1. Check**

- a) electric connection
  - electric wire (1)

**OBS:** If the machine will not start, the phases must be changed.

- b) Knives (3)
  - general condition - sharpness
- c) Waste - room for waste
- d) Safety devices
  - fitting of all safety devices:
    - safety guard for knives (4)
    - safety guards on fences (5)
- e) Table and table extension
  - cleanliness and undamaged surfaces

#### **2. Adjustments:**

- a) The angle of the fences (6)  
(Adjustment instructions page E- 3)
- b) Length of moulding (7)  
(Adjustment instructions page E- 4)
- c) Rebate supports (8)  
(Adjustment instructions page E- 5)
- d) Moulding Clamps (9)  
(Adjustment instructions page E- 6)
- e) Length of stroke  
(Adjustment instructions page F-7)
- f) Conveying  
(Adjustment instructions page F-8)



**Beware of the extremely  
sharp knives**

**Degree Adjustment of Fences - Exact Adjustment of the Fences**

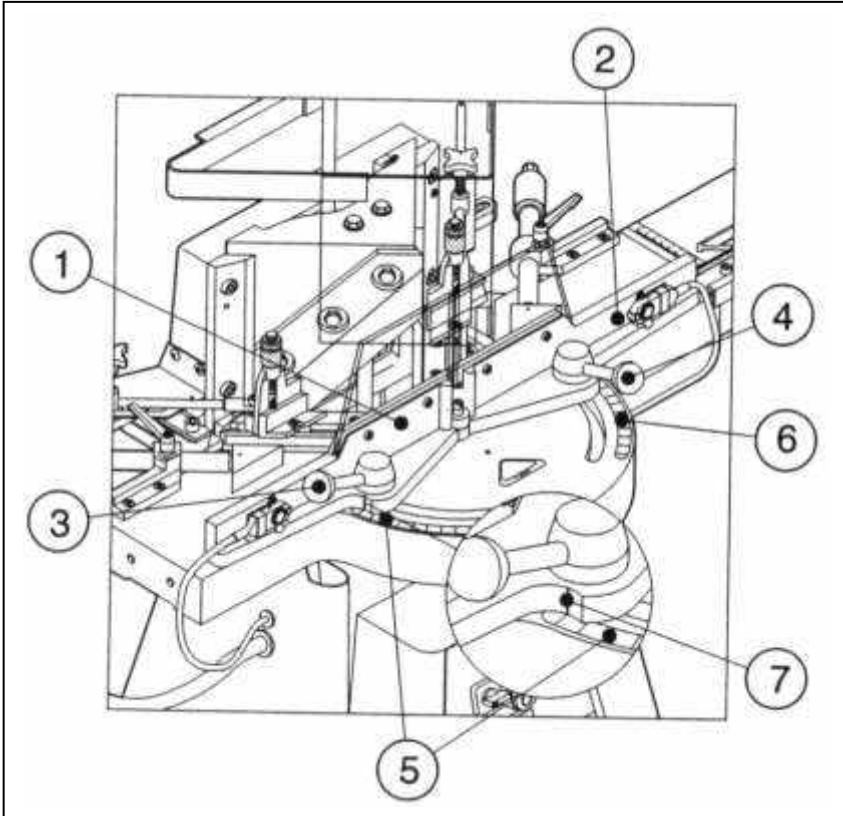

**E-3-1**

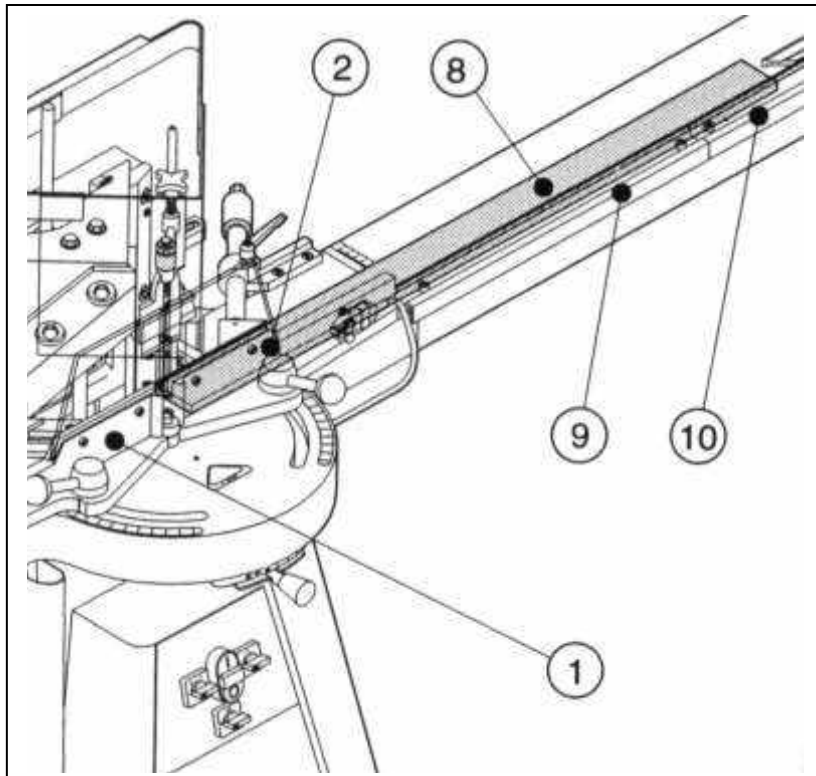

**E-3-2**

### ***Degree Adjustment of Fences***

**(Fig. E-3-1)**

The fences (1) + (2) are adjusted as required (from the factory they are adjusted to 45° for double mitre).

If, for instance, you want to make a 6-sided (hexagonal) frame the following procedure is used:

6 pieces of moulding are cut in the normal way at 45° so that the inside measurement of each piece of moulding is equal to the finished inside measurement of the frame plus approx. the width of the rebate.

Hand levers (3) and (4) are loosened and the fences are turned according to the scales (5) and (6) to 60°.

The degree adjustment is read by means of the mark (7).

After the adjustment the hand levers (3) and (4) are fastened again, and all moulding ends are cut separately at 60° - single mitre.

### ***Exact Adjustment of the Fences:***

**(Fig. E-3-2)**

When the fences have been adjusted to degrees other than 45°, the correct re-adjustment to 45° is made as follows:

Place a straight steel rule (8) against the measuring scale (9) so that it also reaches along the right fence (2). Now, adjust the right fence (2) according to the steel rule, and the right fence (2) will be exactly adjusted at 45°.

Place the steel rule (8) against the right fence (2) (now exactly adjusted at 45°), so that it also reaches along the left fence (1). Adjust the left fence (1) according to the steel rule, and the left fence will be exactly adjusted at 45°.



**Beware of the extremely sharp knives**

**Adjustment of Length of Moulding**

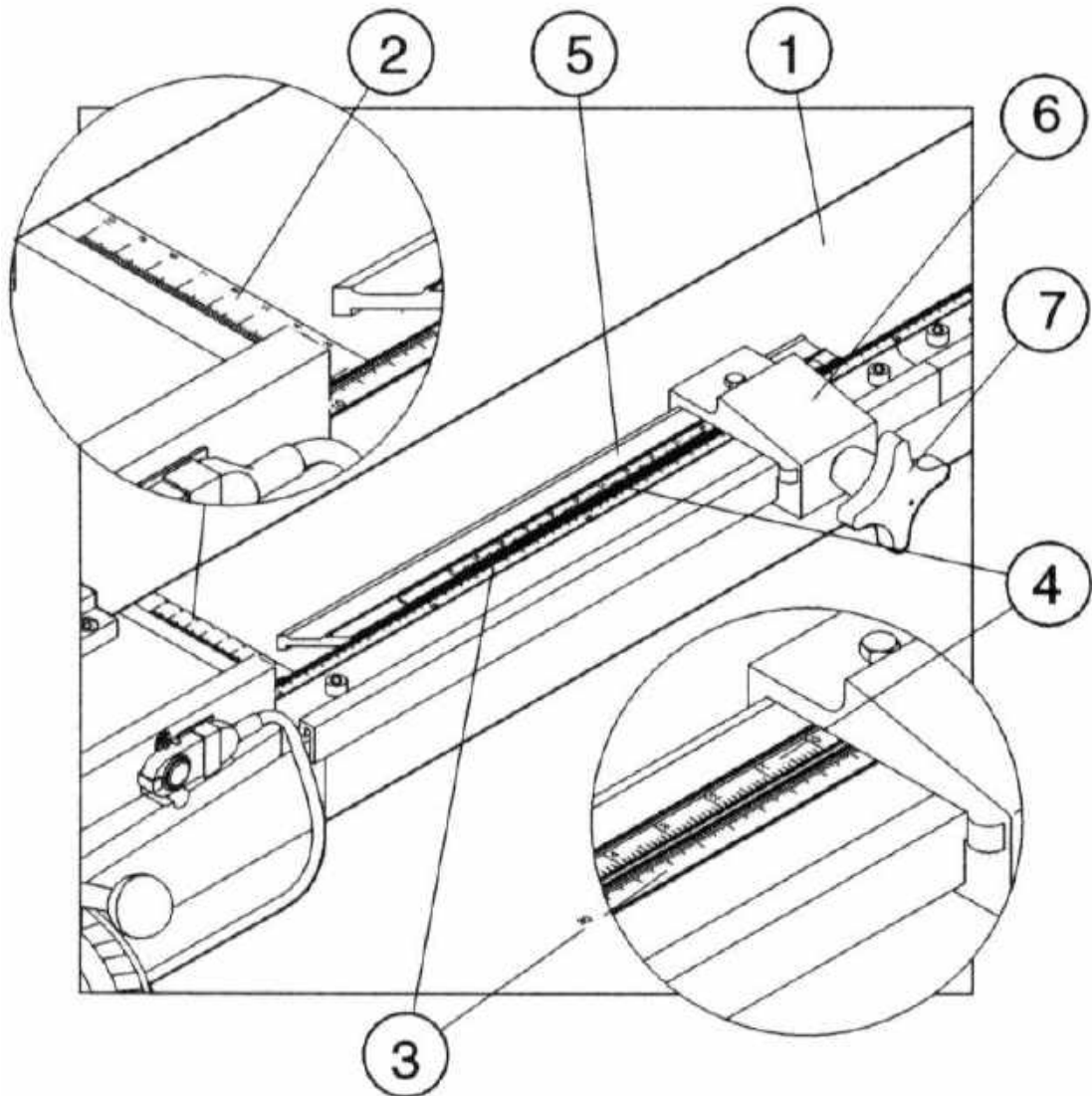

### ***Adjustment of Length of Moulding***

**Principle:**

The inside measurement of a frame = outside measures less 2 times the width of the moulding (if both ends are cut at 45°.)

The width of the moulding is measured by means of the measuring scale (2) on the table (1). The length of the moulding is measured by means of the measuring scale (3) on the table (1) and the measuring scale (4) on the stop beam (5). The measuring scale (4) on the stop beam (5) is carried out in double measures.

**Example 1:**

**Outside measures of the frame:**

1. Star wheel (7) on stop block (6) is loosened.
2. The required length of moulding is 29 cm.  
The mark "0" on scale (4) on stop beam (5) is adjusted exactly opposite the 29 cm mark on the measuring scale (3) on the table.  
The outside measures of the frame will be 29 cm.
3. Star wheel (7) is tightened.

**Example 2:**

**Inside measures of the frame:**

1. Star wheel (7) on the stop block (6) is loosened.
2. The width of the moulding, excl. the rebate (e.g. 3.5 cm) is read off the scale (2) on the table.
3. The required length of moulding is 27 cm.  
The 3.5 cm mark on scale (4) on the stop beam (5) is adjusted exactly opposite the 27 cm mark on the measuring scale (3) on the table.  
The inside measures of the frame will be 27 cm.
4. Star wheel (7) is tightened.



**Beware of the extremely sharp knives**

**Measuring Scale De-Luxe**

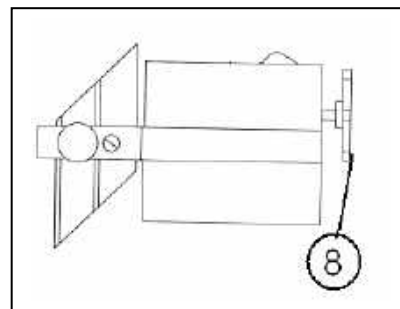
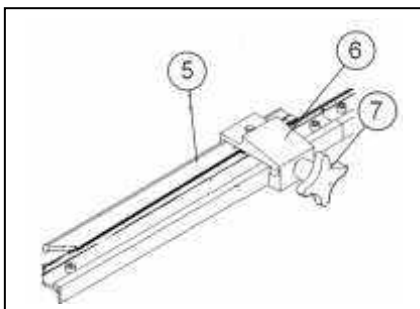
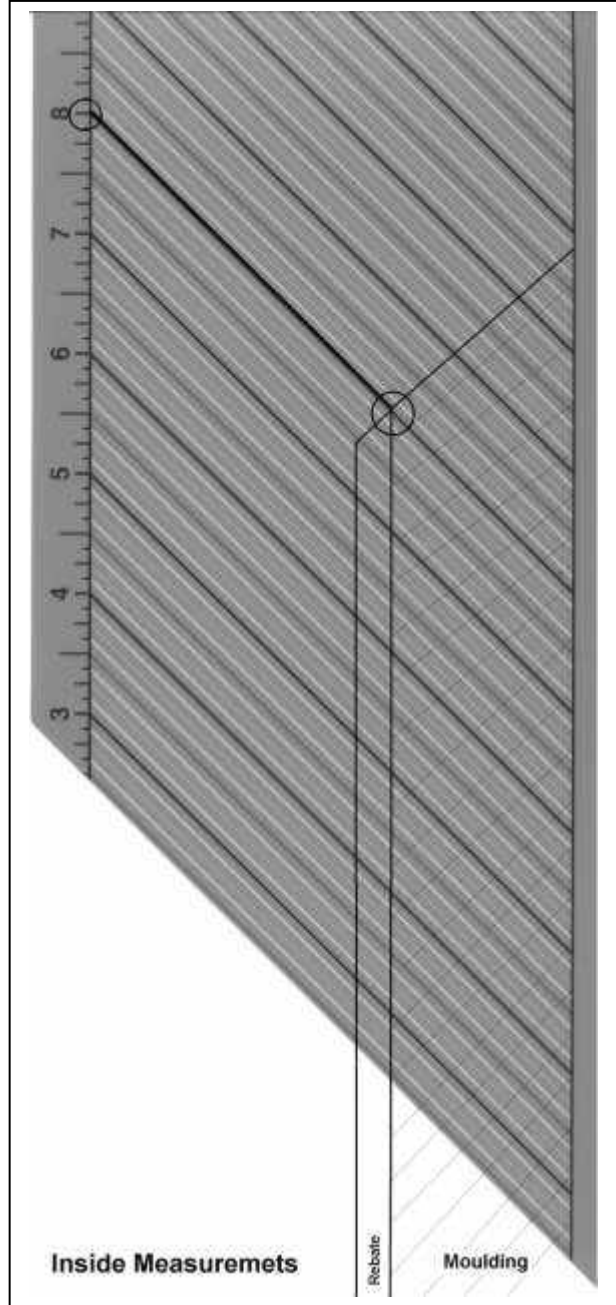
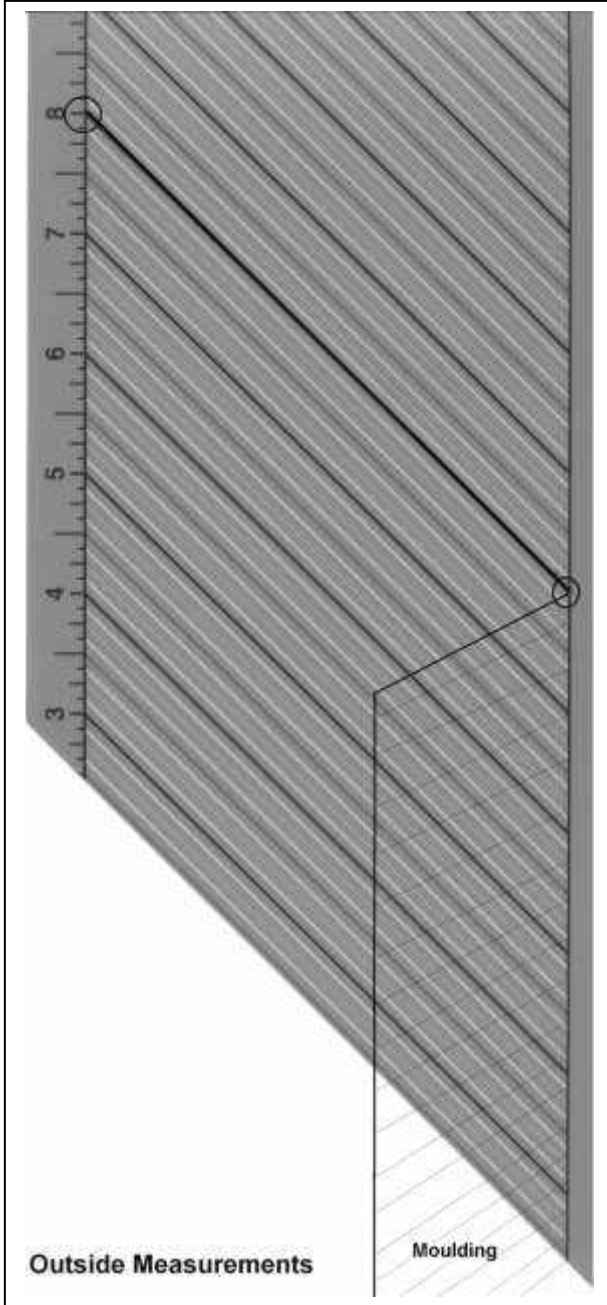

**E-4-1**



### **Measuring Scale De-Luxe**

#### **Principle:**

The measuring scale engraved in the table indicates the distance from the right knife in inches. E.G. the line marked 8 has a distance of 8 inches from the right knife.

#### **Outside measurement:**

To make a frame of 8 x 6 inches outside measurement proceed as follows:

Cut the right hand side of the moulding to 45°. Place the moulding on the table so that the end of the moulding is exactly at the line marked 8.

Push the movable stop beam (5) against the end of the moulding, and tighten it by means of the stop block (6) and star wheel (7).

Cut two pieces of moulding.

Repeat the procedure as described above, but use the line marked 6 instead of 8.

#### **Inside measurement:**

To make a frame of 8 x 6 inches inside measurement proceed as follows:

Cut the right hand side of the moulding to 45°. Place the moulding on the table so that the corner between the start of the rebate and the end of the moulding is exactly at the line marked 8.

Push the movable stop beam (5) against the end of the moulding, and tighten it by means of the stop block (6) and star wheel (7).

Cut two pieces of moulding.

Repeat the procedure as described above, but use the line marked 6 instead of 8.

You can now make a frame which fits a picture of 8 x 6 inches.

*The same procedure is adopted for machines engraved in metric.*

#### **Second Stop (Flip-over stop)**

The second stop is used when cutting short - long lengths of the frame. The second stop is adjusted to the short length as follows:

Adjust the measuring scale as described above to the short length of the frame. Cut a piece of moulding in the short length. Put the knives in bottom position, push the short length of the moulding up against the knives. The second stop is pushed against the end of the moulding and fastened by means of star wheel (8). Flip it over.

Adjust the measuring scale as described above to the long length of the frame.

You can now cut short - long lengths - the long length by flipping over the second stop.



**Beware of the extremely  
sharp knives**

**Adjustment of Rebate Supports and Moulding Clamps**

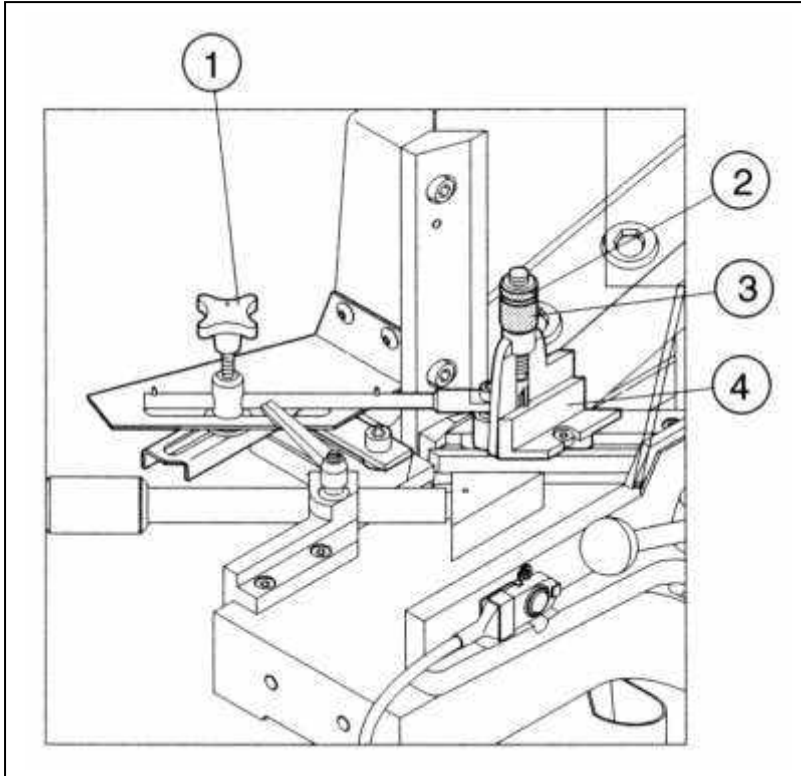

**E-5-1**

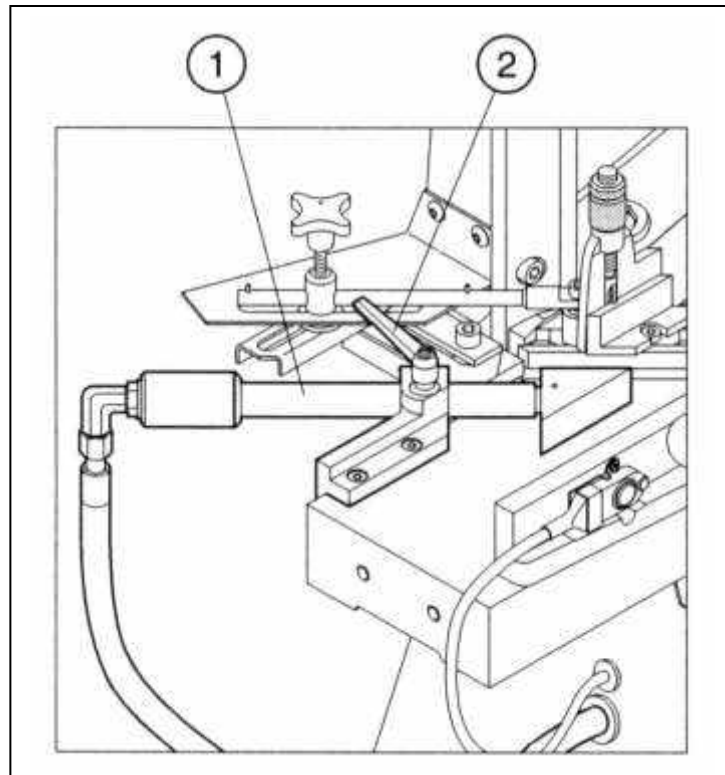

**E-5-2**

### ***Adjustment of Rebate Supports (fig. E-5-1)***

#### **The knife block must be in the top most position during the adjustment**

The rebate supports are only used when cutting mouldings with rebates.

To adjust the rebate supports star wheel (1) and knurled nut (2) are loosened.

Place the moulding to be cut in the machine. Push the rebate supports (4) into the rebate of the moulding.

Press the moulding down on the machine table.

The height of the rebate supports is adjusted by means of the knurled nut (3). The rebate supports must be adjusted so that they are approx. 1/2 mm under the rebate of the moulding.

After the adjustment the knurled lock nut (2) is tightened.

The rebate supports are fastened with star wheel (1) so that they have a distance of about 1/2 mm from the moulding.

The rebate supports can be removed from the machine when the knife block is in the rear most position.

### ***Adjustment of the Moulding Clamps (fig. E-5-2)***

The moulding clamps work electrically and continuously.

The length of stroke is 10 mm.

The moulding to be cut is placed in the machine.

The tightening lever (2) is loosened and the moulding clamps (1) are pushed against the moulding. Then the moulding clamps are drawn approx. 3 mm backwards.

After the adjustment the moulding clamps are fastened with tightening lever (2).



**Beware of the extremely sharp knives**

**Working Procedure**

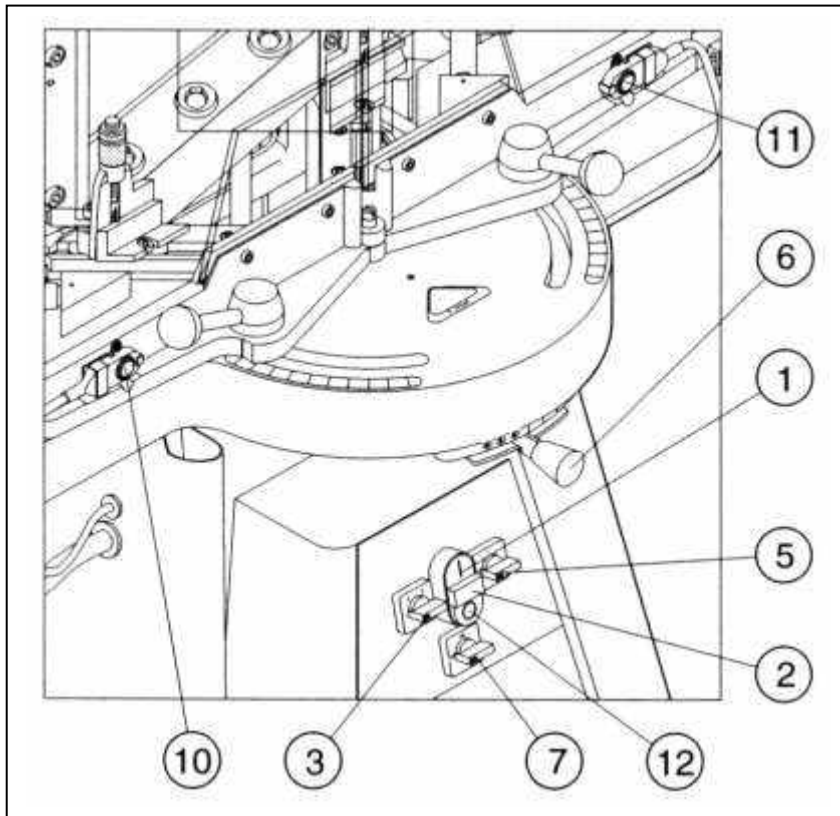
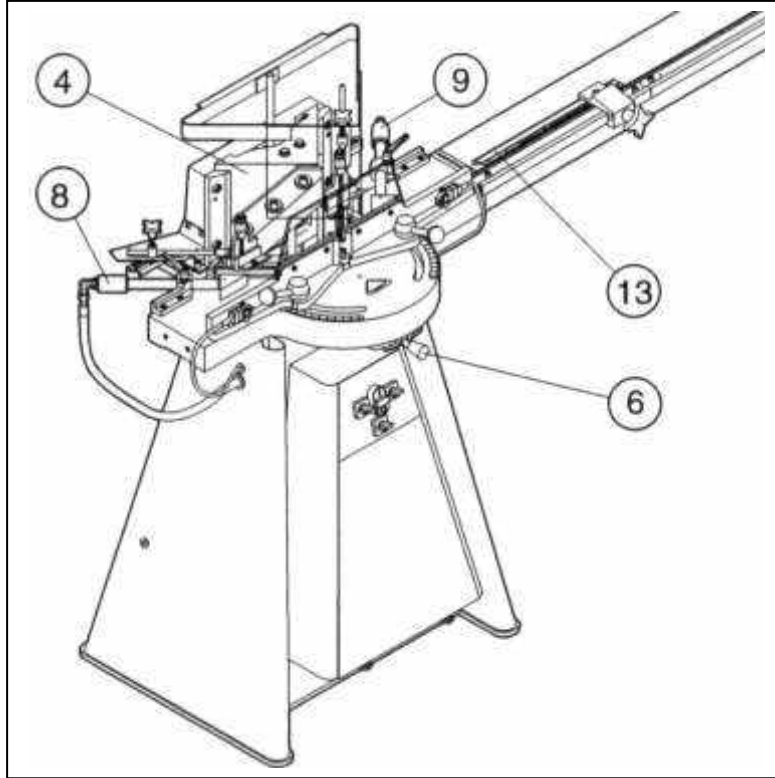

### **Working Procedure**

The machine is switched on by starting switch "I" - green (1) (the lamp (2) has a light).

Place the moulding on the machine table and push it up to the adjusted stop beam (13).

With the switch (3) the required length of stroke of the knife block (4) is adjusted:

Position 1 = shortest length of stroke  
Position 2 = second length of stroke  
Position 3 = full length of stroke

With the switch (5) the automatic conveying is adjusted:

Position 0 = the automatic conveying is inactive  
(manual adjustment without function).  
Position 1 = the automatic conveying is active  
(the rear position of the slide frame is adjusted manually with handle (6) between 10 and 60 mm).

Switch (7) activates the moulding clamps (8) + (9):

Position OFF = Moulding clamps disconnected.  
Position ON = Moulding clamps connected.

Activate pushbutton switch (11) - the moulding clamps are tightened and the knife block goes forward to the cutting position with the automatic cycle of two cuts.

Activate both pushbutton switches (10) + (11) simultaneously and the cutting procedure starts.

After finished cutting cycle the moulding clamps are automatically released.

The machine is switched off by switch - red "O" - red (12) (the lamp (2) is turned off). See description of cutting page B-4.

### **After Working Procedure – Cleaning**

Remove the wire from the wall socket. The machine is checked and cleaned thoroughly. Remove any waste wood from the guidings and from behind the machine.

Keep the electric system free from waste and cover. This might cause over-heating in the electric motor.

Resin from the mouldings can sometimes cause the knife blades to drag on the upward action of the knife block. To remove this resin, use WD 40, sprayed onto a cloth made in the shape of a ball (so that your fingers never go near the knives). Wipe in a downward action only so that neither the cloth nor your fingers can come into contact with the cutting edge of the knives.



**Beware of the extremely sharp knives**

**Lubrication Instructions**

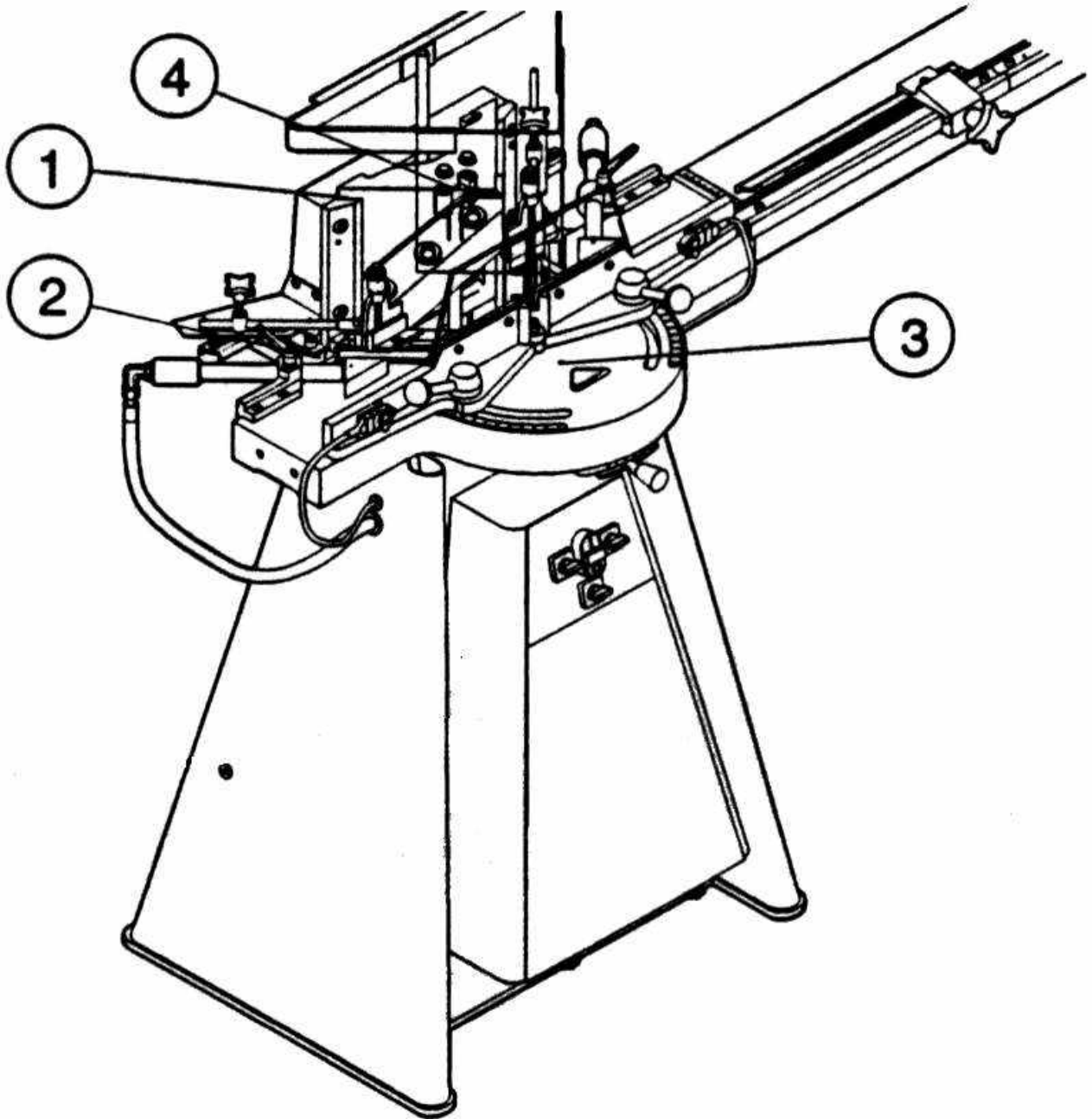

### ***Lubrication Instructions***

Approx. every two weeks lubricate:

The guidings for:

1. Knife block (1)
2. Slide frame (2)
3. Cross (3)
4. Links for the draw bar (4) of the knife block.

**Lubricant:** SHELL TONNA TEX 68 or a similar oil of another make.



**Beware of the extremely  
sharp knives**

**Changing Knives**

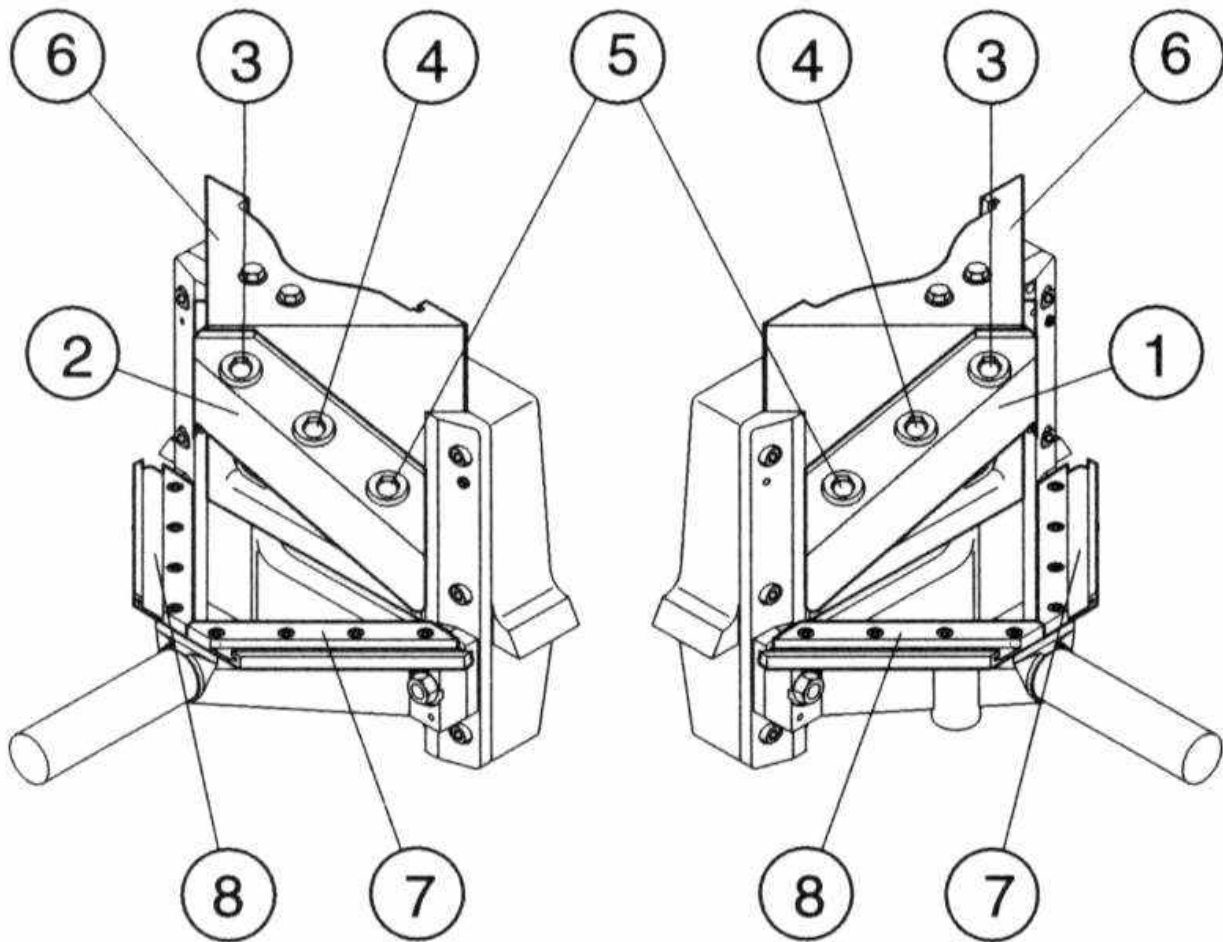



### **Changing Knives**

When the cutting is no longer satisfactory, e.g. unclean cut surfaces with grooves, the knives must be changed or sharpened.

#### Precautions recommended:

Place a block of wood 2 mm below the knives so they cannot drop.

TESA type tape can be used to cover the cutting edge of the knives to safeguard both the blades and our fingers during removal and refitting.

1. Bolts (3), (4) + (5) are loosened with spanner (17mm.).
2. Remove bolts (3) + (5).
3. Remove bolt (4) from knife (1) while pressing the knife against the knife block (6) with you hand so that the knife does not fall down.
4. Remove the knife.  
**TAKE CARE OF YOUR FINGERS.**
5. The same procedure is adopted with the opposite knife (2).
6. Clean the surfaces of the knife block (6) and the new knives very carefully as even the smallest impurity between knife and knife block (6) will cause the knives to impinge too hard against the bottom knives (7) + (8).
7. Both new knives (1) + (2) are fitted on the knife block (6) with the bolts (3) + (5). Do not tighten the bolts.
8. The knives are pressed together at the front point. The knives must meet precisely at the front point and neither front edge must be further ahead than the other.
9. Check if the cutting edges of the knives are exactly the same height. If not, the knives can be adjusted up or down separately until the correct position is reached.
10. Tighten the bolts (3) (in both knives).
11. Insert the bolts (4) and tighten them.
12. Tighten bolts (5)
13. Start the machine.
14. Make a trial cut.
15. If in the slightest doubt about this repair, then call a qualified engineer.



**Beware of the extremely  
sharp knives**

**Grinding of Knives**

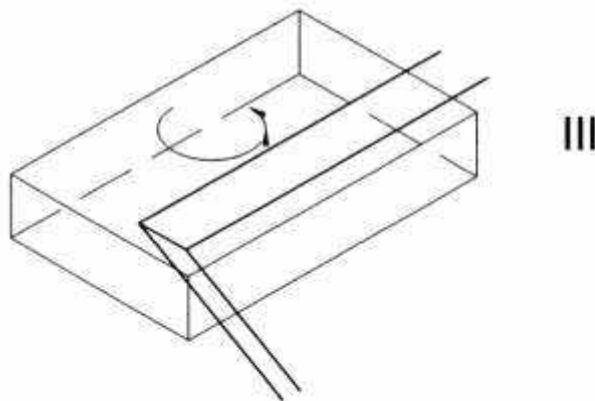
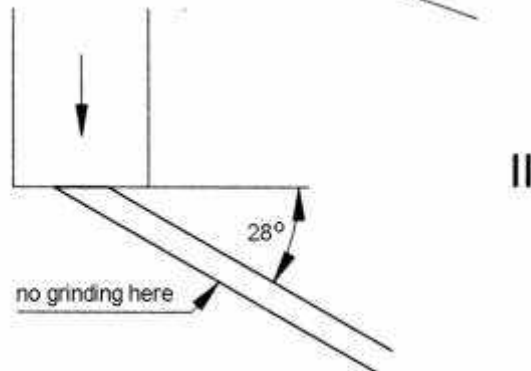
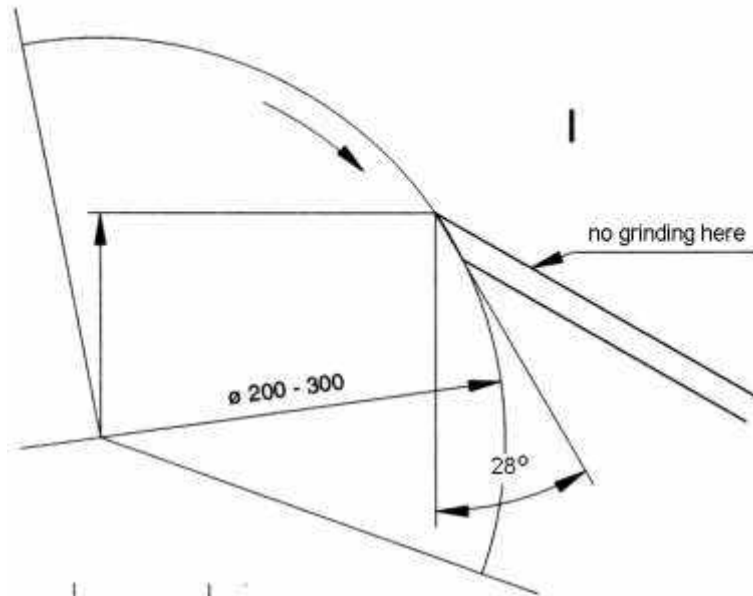

### **Grinding of Knives**

When grinding the knives you must **only** grind on the reverse of the cutting edge. You must under **no circumstances** grind on the front or ends of the knives, because the knives will then be destroyed. The angle of the cutting edge compared to the front of the knife must be 28°.

**Hollow grinding** (recommended), figure I.

Using a grinding wheel the diameter must be between 200 - 300 mm. Using a cup wheel the diameter must be 150 mm.

**Surface grinding** figure II

**Honing** figure III

By setting the cutting edge you must use a soft fine-grained silicon carbide hand flat stone that must be kept soaked in oil or kerosene.

By setting the cutting edge you must under **no circumstances** sharpen lengthwise of the cutting edge, always crosswise.

First sharpen on the reverse side of the knife. The flat stone is to be kept in an angle of 29° compared to the front of the knife.

**Take off burrs**, figure IV

After the honing the burrs on the front of the knife are taken off with a slate flat stone that must be quite straight.

The flat stone must here be completely in line with the knife, because otherwise the outer cutting edge will get an incorrect angle.

Even the slightest error here will cause the knife to press too hard against the wood during the cutting, causing damage or bruising to the moulding.



**Beware of the extremely sharp knives**

**Changing of Spare Parts**

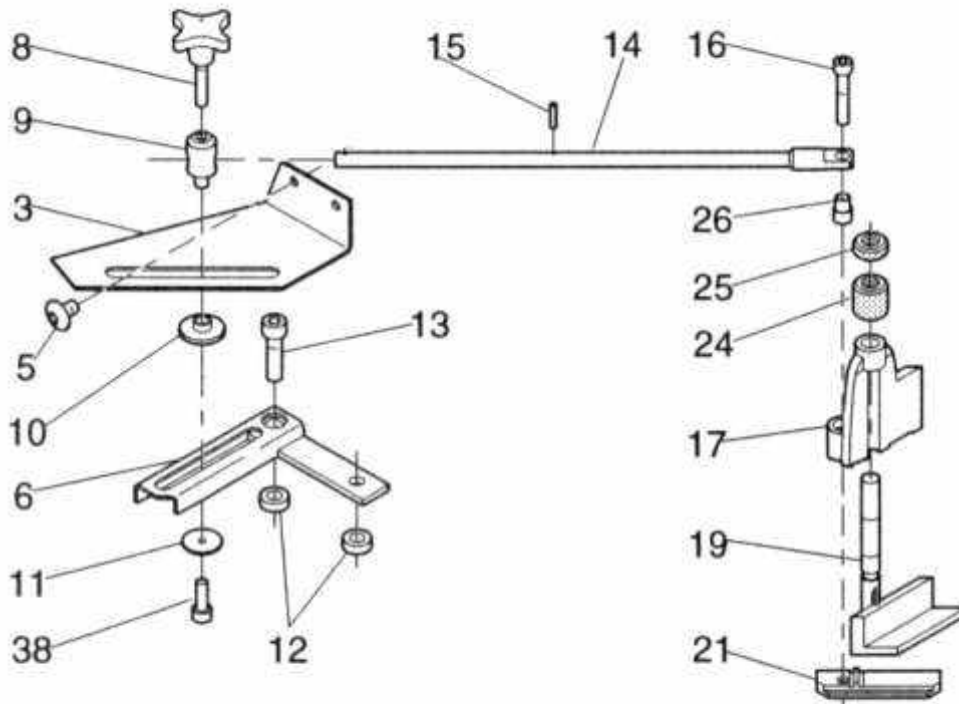

If it is necessary to change worn out or damaged parts we recommend that you proceed in the following manner:

1. The index of the spare parts list (see page I-1) refers to which specific list the spare part can be located.
2. The list in question is then used when ordering spare parts, as there are part numbers, disassembly and assembly diagrams of the part in question.
3. Example:  
Parts in the rebate support must be renewed:  
Figure I-1 shows that the parts are located in figure I-6. Under Pos. 1, 2, and 4, the parts necessary for the replacement, disassembly and assembly procedure is illustrated.  
In the text part of the illustration the order number and spare part designator are stated.

If in doubt, you should call a qualified engineer.



### **Adjustment of Stroke of the Knife Block**

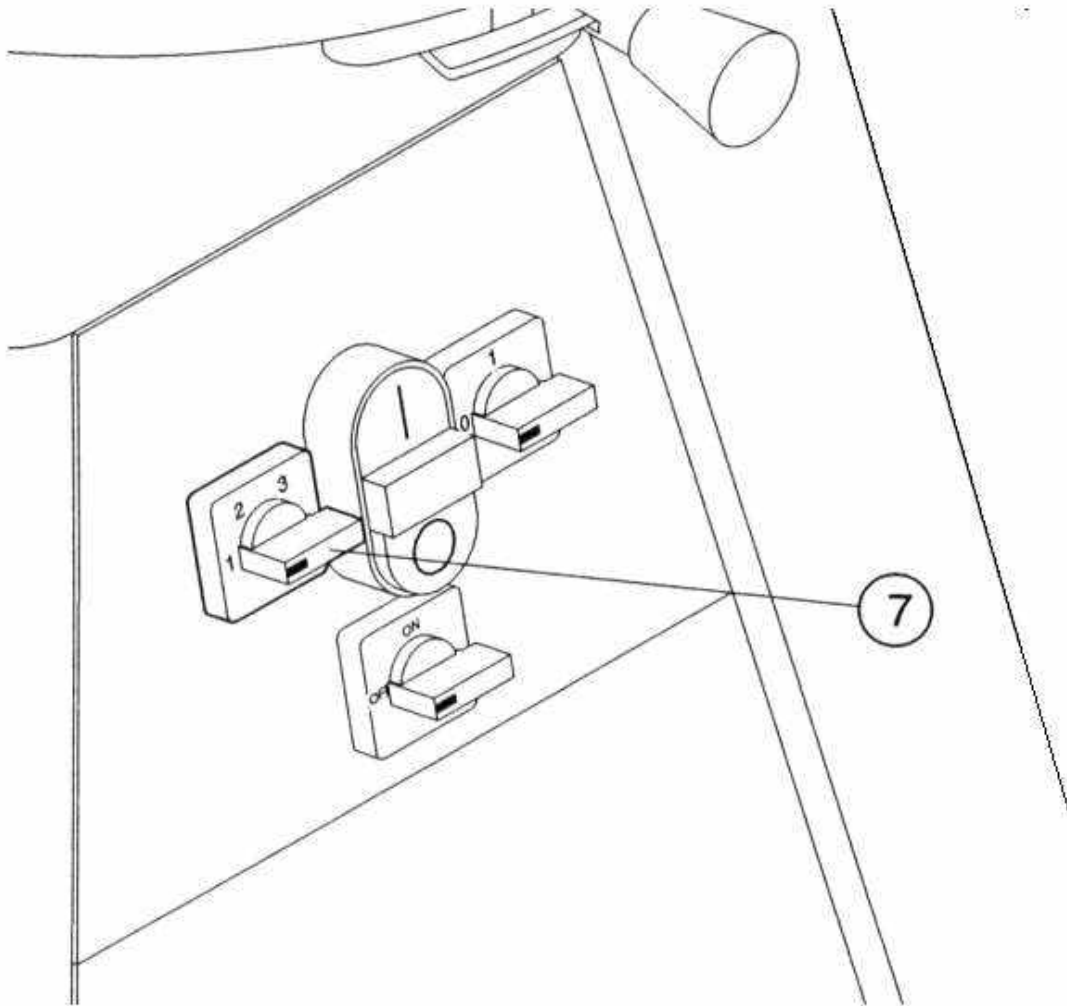

The length of stroke of the knife block can be changed with the switch (7):

Position 1 = **shortest** length of stroke

Position 2 = **middle** length of stroke

Position 3 = **full** length of stroke

### Adjustment of End Stop for Conveying

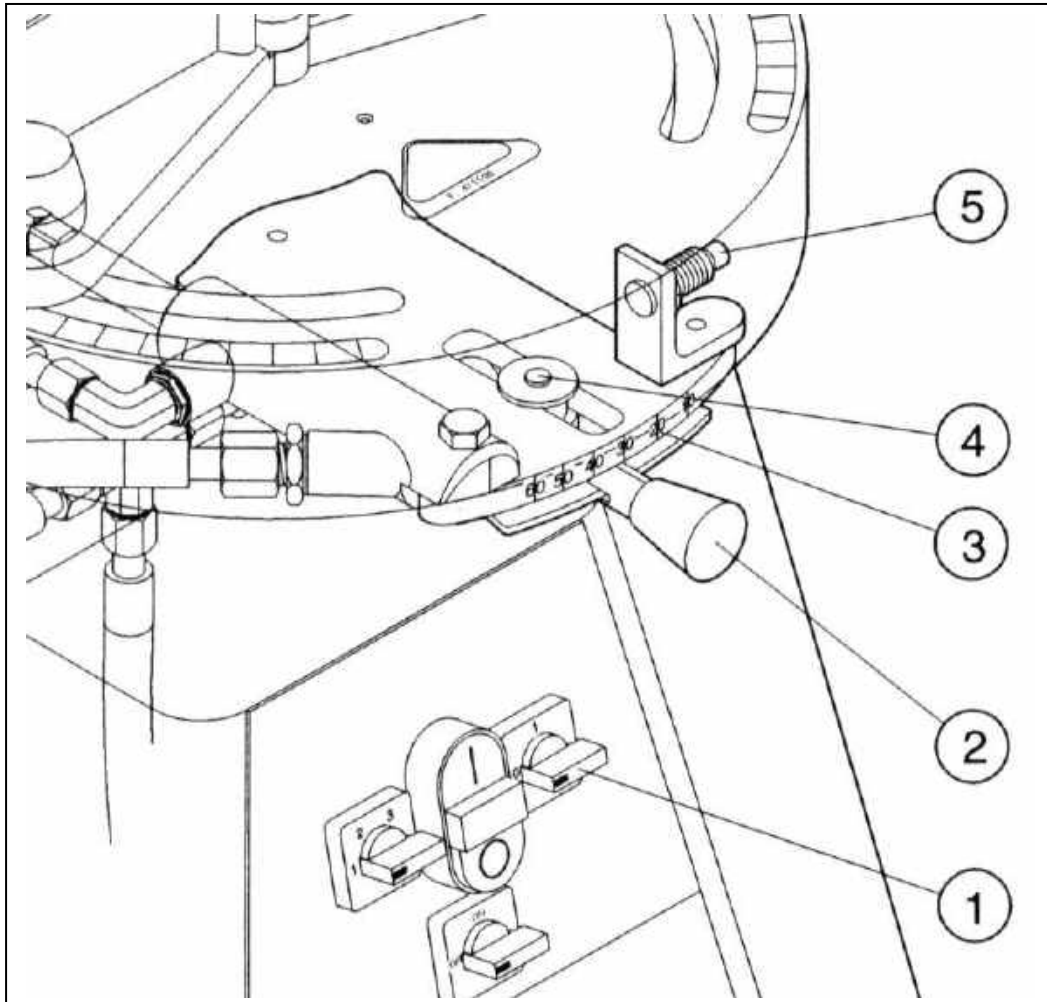

The rear position of the slide frame can be adjusted as required.

1. Switch (1) in position "0" (trim cycle)

The automatic conveying is inactive.

2. Switch (1) in position "1"

The automatic conveying is active.

The rear position of the slide frame can be adjusted stepless with handle (2) between 10 and 60 mm according to scale (3).

After the cutting process the slide frame always goes back to the adjusted rear position.

3. The adjustments of the inductive tracer (4) and (5) must not be changed.

**Adjustment of Inductive Tracers:**

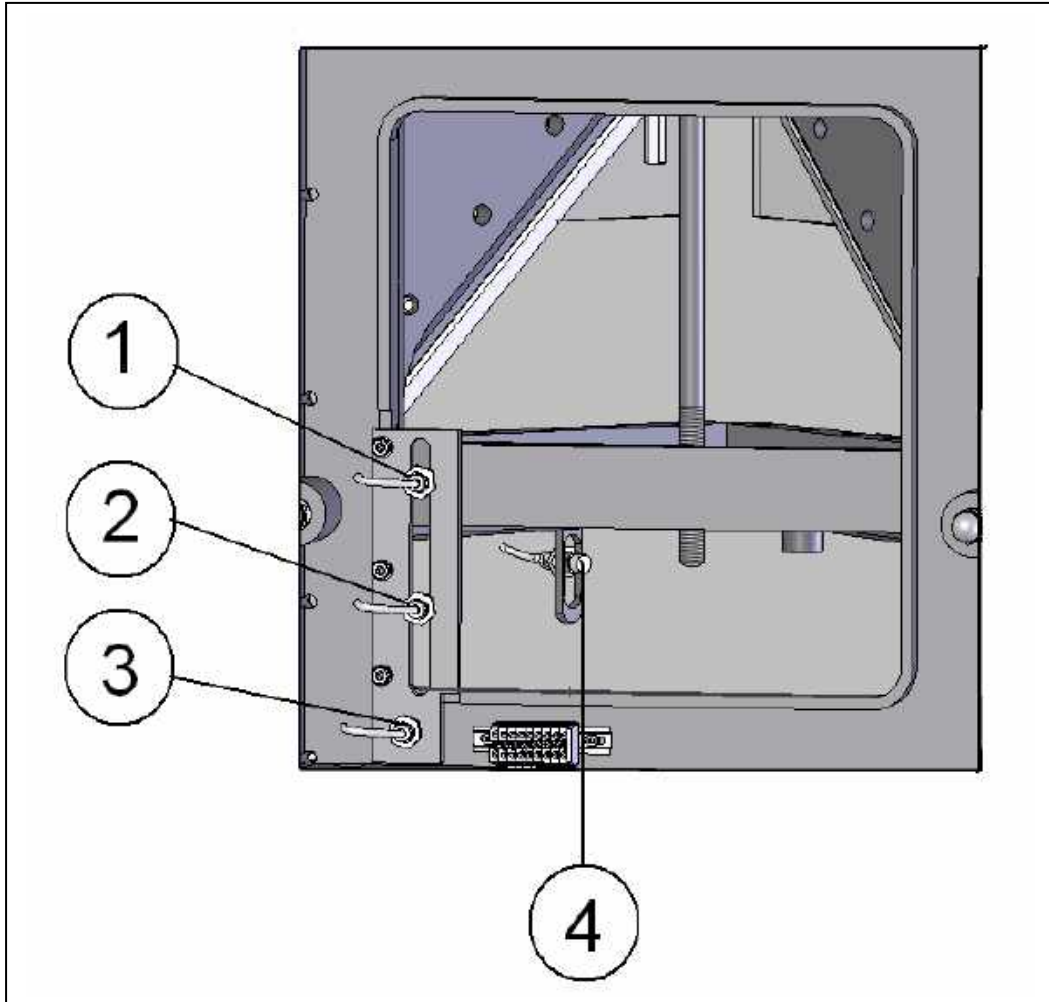

1. Inductive tracer (1) for full length of stroke
2. Inductive tracer (2) for middle length of stroke
3. Inductive tracer (3) for shortest length of stroke
4. Inductive tracer (4) for bottom stop



**Beware of the extremely sharp knives**

**Adjustment of number of cuts**

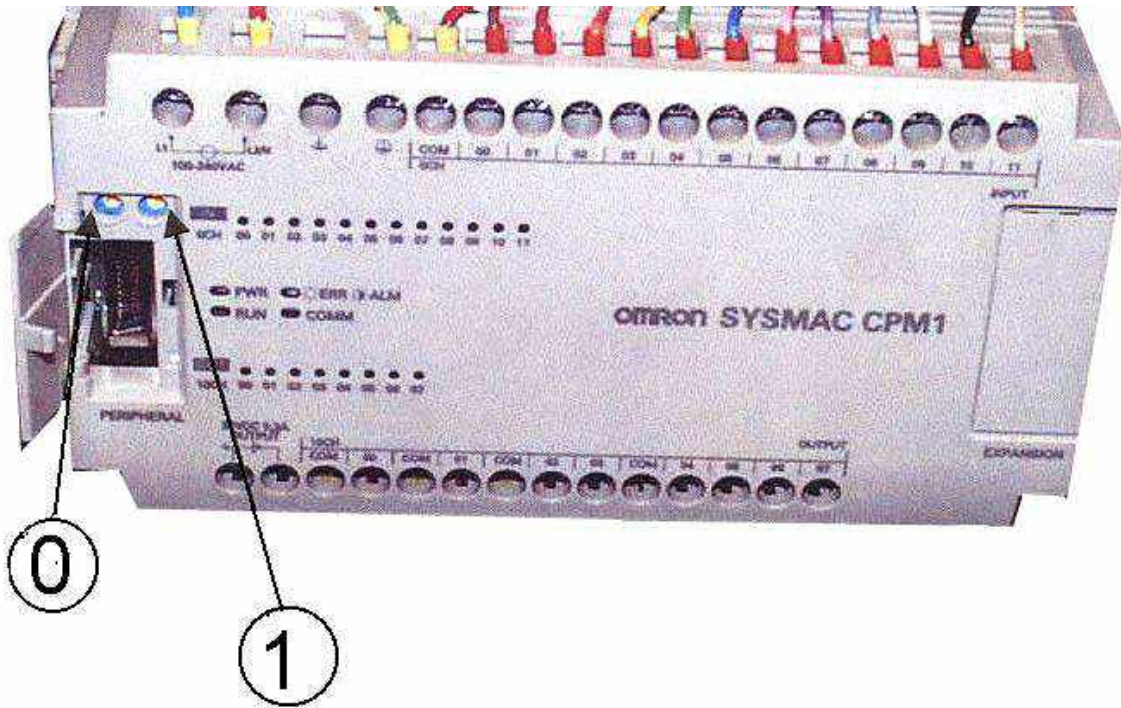

**Adjustment of number of cuts**

Turn the little screw (0) clockwise to increase the number of cuts and anticlockwise to reduce the number of cuts.

**BE AWARE THAT THIS LITTLE SCREW REACTS ON A VERY VERY SLIGHT TOUCH**

**Adjustment of return stroke**

Turn the little screw (1) clockwise to increase the return stroke and anticlockwise to reduce the return stroke.

**BE AWARE THAT THIS LITTLE SCREW REACTS ON A VERY VERY SLIGHT TOUCH**



<b>Faults</b>	<b>Cause</b>	<b>Repair</b>
Incorrect cuttings	Blunt knives	Replace/resharpen the knives See page F-2/ F-3
	Knives incorrectly installed	Check the installation See page F-2
	2 mm sensor not functioning correctly	Check 2 mm sensor
Moulding with rebate tips	Rebate support incorrectly adjusted	Correct the adjustment See page E-5
The moulding is not firm on the table during cutting	The Moulding clamps incorrectly adjusted	Correct the adjustment See page E-5
	Fences loose	Fasten fences See page E-3
The machine does not start	Connecting cable not connected	Put the cable in the wall socket.
	Connecting cable destroyed	Exchange the connecting cable
	Incorrect activation of start button	Start again
	Fine fuse destroyed due to overloading	Find out why the overloading arises and exchange the fine fuse
	Blue re-set button cut out	Check blue re-set button
The machine stops during cutting	Relays/fuses not functioning	Check relays/fuses
	Motor over-heated	Remove the waste from the housing Press the thermal cut-out on the fitting plate
	Blue re-set button cut out	Check blue re-set button
	Relays/fuses not functioning	Check relays/fuses
Incorrect length measurement	The length measure incorrectly set	Correct the length measure See page E-4
	Stop beam loose	Fasten stop beam
Knife block does not go up or down	Check if the machine is wired correctly	
	Sensor not functioning correctly	Check sensor
	Push buttons not functioning correctly	Check pushbuttons See page E-1
Knife block does not go forward or backwards	Transit locking pin not removed	Remove transit locking pin See page D-1
	Push buttons not functioning correctly	Check pushbuttons See page E-1
Moulding clamps do not work	The switch on OFF position	Put switch on ON position See page E-1

### **Safety Devices**

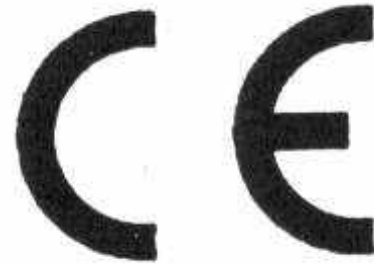
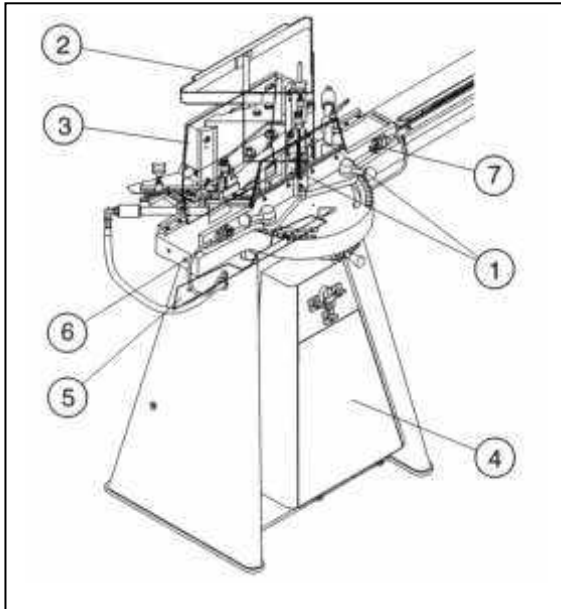

According to current safety regulations **MORSØ E Future Green** must not be used without the following safety devices:

1. Safety Guards (1) in the fences
2. Safety Guard (2) for knife block
3. Safety Guard (3) for slide frame.
4. Front Plate (4) for electric control
5. Waste Slide (5) over the spindle.
6. Distance between the push buttons on the fences (6) + (7) must not be changed.

### **Safety Regulations**

On delivery of the machine to the consumer



guarantees that **MORSØ E Future Green** mitring machine complies with CEN/TC 142 (Safety Regulations for wood working machinery).

Before using the mitring machine **MORSØ E Future Green** the operator must be familiar with current national and international safety regulations.

If the operator does not comply with the above mentioned regulations the factory is not liable for damages to either the machine or the operator.

**0095**  
**Oversigt - Index - Übersicht**

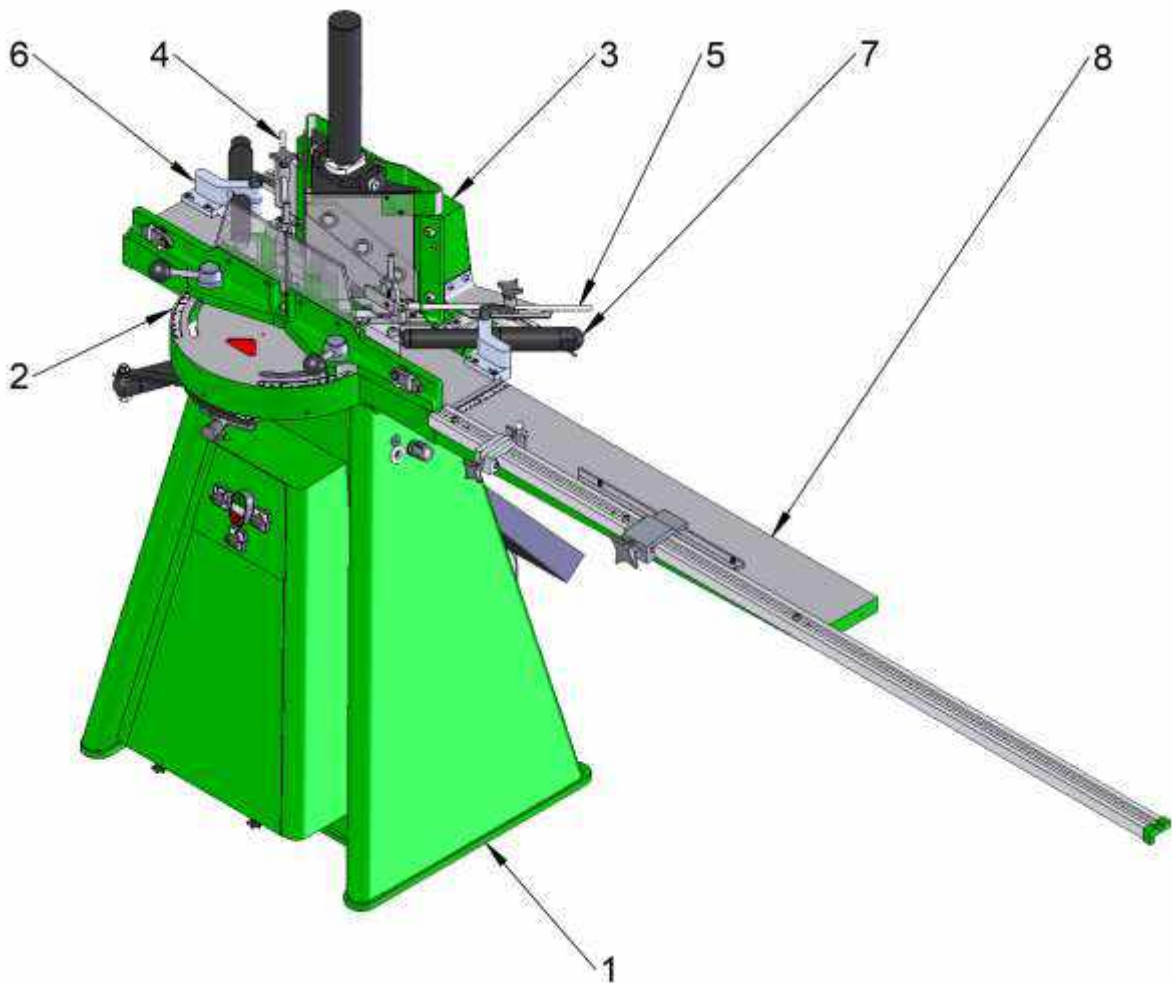

Pos	Art.No.	Betegnelsen	Designation	Benennung
1	00951000	Grundmaskine, komplet	Basic Machine, complete	Grundmaschine, komplett
2	00952000	Bord, komplet	Table, complete	Tisch, komplett
3	00953000	Knivhovedenhed, komplet	Knife Block Unit, complete	Messerkopf-Einheit, komplett
4	01400345	Falsstøtte, komplet, V	Rebate Support, complete, L	Falzauflage, komplett, L
5	01400345	Falsstøtte, komplet, H	Rebate Support, complete, R	Falzauflage, komplett, R
6	00953045	Listeholder, komplet, V	Moulding Clamp, complete, L	Leistenhalter, komplett, L
7	00953045	Listeholder, komplet, H	Moulding Clamp, complete, R	Leistenhalter, komplett, R
8	00954000	Bordforlænger, komplet	Table Extension, complete	Tischverlängerung, komplett

Rev. 2020.03.20

00951000

**Grundmaskine, komplet - Basic Machine, complete – Grundmaschine, komplett**

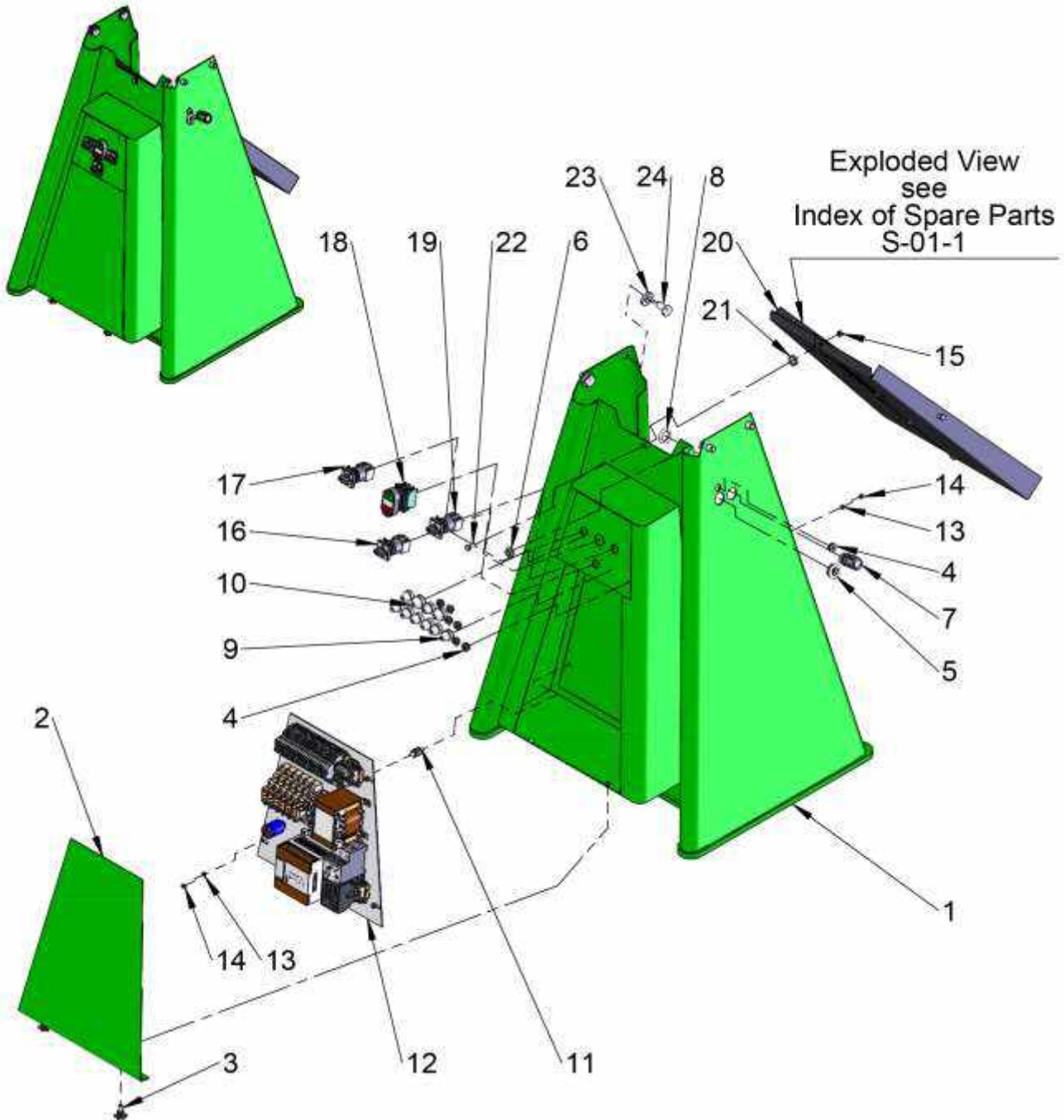

**00951000**
**Grundmaskine, komplet - Basic Machine, complete – Grundmaschine, komplett**

Pos	Art.No.	Betegnelse	Designation	Benennung	Pcs
1	08500327	Stativ	Frame	Gestell	1
2	02603543	Klemkasse front/bund	Cover, front/bottom	Deckel, Front/Boden	1
3	45060813	Fingerskrue	Finger Screw	Fingerschraube	2
4	62006645	Gennemføring	Cabling	Kabeldurchführung	8
5	62006662	Gennemføring	Cabling	Kabeldurchführung	2
6	62006650	Gennemføring	Cabling	Kabeldurchführung	1
7	62003300	Kabelgennemføring	Cabling	Kabeldurchführung	1
8	62003305	Møtrik	Hexagon nut	Sechskantmutter	1
9	62057710	Kabelgennemføring	Cabling	Kabeldurchführung	8
10	62057712	Kabelgennemføring	Cabling	Kabeldurchführung	2
11	62005000	Vibrationsdæmper	Oscillation Damper	Schwingungsdämpfer	4
12	02610543	Styring, komplet	Control, complete	Steuerung, komplett	1
13	41000005	Fjederskive FXB 5 mm	Spring Washer FZB 5mm	Federscheibe FZB 5 mm	8
14	43000005	Møtrik M5	Hexagon Nut M5	Sechskantmutter M5	8
15	43000006	Møtrik M6	Hexagon Nut M6	Sechskantmutter M6	1
16	62000053	Omskiftergreb on-off, komplet	Switch on-off, complete	Schalter on-off, komplett	1
17	62000055	Omskiftergreb 1-2-3, komplet	Switch 1-2-3, complete	Schalter 1-2-3, komplett	1
18	62000050	Start/Stop kontakt, komplet	Start/Stop Switch, complete	Start/Stop Schalter, komplett	1
19	62000051	Omskiftergreb 0-1, komplet	Switch 0-1, complete	Schalter 0-1, komplett	1
20	00950000	Spånskærm, komplet	Waste Chute, complete	Abfallrutsche, komplett	1
21	02500020	Bøsning 20x4 mm (EH)	Bushing 20x4 mm (EH)	Buchse 20x4 mm (EH)	1
22	53006016	Sætskrue FZ M6x16	Set Screw FZ M6x16	Gewindestift FZ M6x16	1
23	80862576	Skive f. stativ	Washer f. Frame	Scheibe f. Gestell	4
24	55711220	Stålbolt	Hexagon Screw	Sechskantschraube	4

**WHEN ORDERING SPARE PARTS, PLEASE STATE SERIAL NUMBER OF THE MACHINE.**

**00950000**

**Spånskærm, komplet - Waste Chute, complete – Abfallrutsche, komplett**

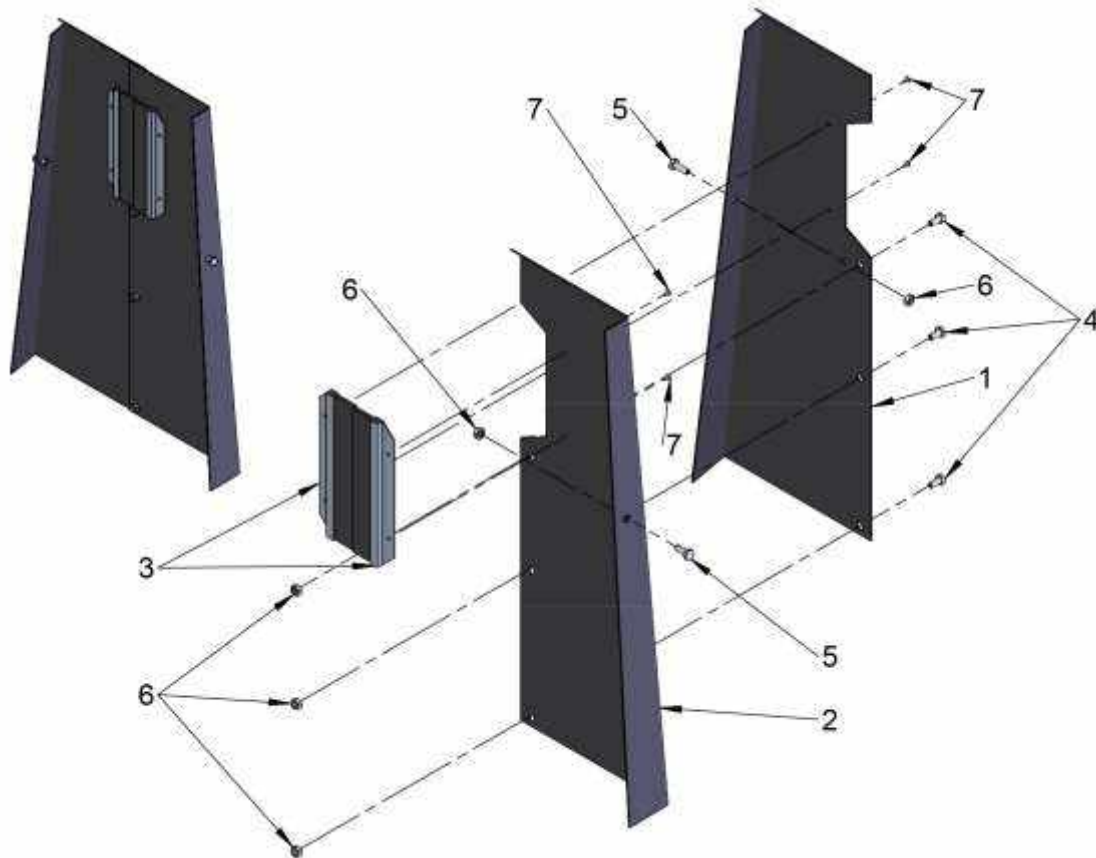

Pos	Art.No.	Betegnelse	Designation	Benennung	Pcs
1	00950000 V	Spånskærm	Waste Chute	Abfallrutsche	1
2	00950000 H	Spånskærm	Waste Chute	Abfallrutsche	1
3	11050100	Børste	Brush	Bürste	2
4	53006012	Sætskrue FZ M6x12	Set Screw FZ M6x12	Gewindestift FZ M6x12	3
5	53006016	Sætskrue FZ M6x16	Set Screw FZ M6x16	Gewindestift FZ M6x16	2
6	43000006	Møtrik M6	Hexagon Nut M6	Sechskantmutter M6	5
7	58000100	Blindnitte Ø3,2x6	Blind Rivet Ø3,2x6	Blindnagel Ø3,2x6	4

**WHEN ORDERING SPARE PARTS, PLEASE STATE SERIAL NUMBER OF THE MACHINE.**

**00952000**  
**Bord, komplet - Table, complete - Tisch, komplett**

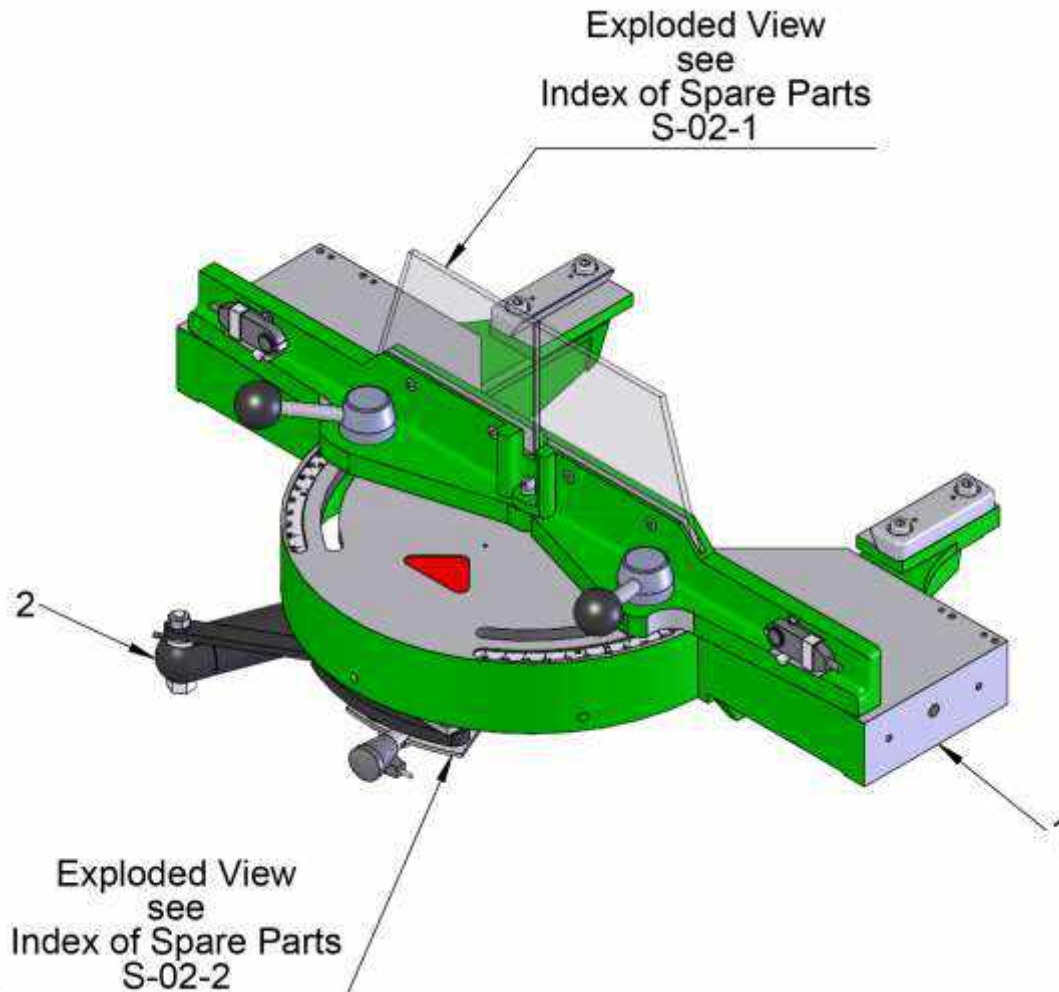

Pos	Art.No.	Betegnelse	Designation	Benennung
1	00952100	Bord	Table	Tisch
2	00952200	Knivhoved, frem/tilbage	Knife Block, forwards/backwards	Messerkopf vorwärts/rückwärts

**00952100**  
**Bord - Table - Tisch**

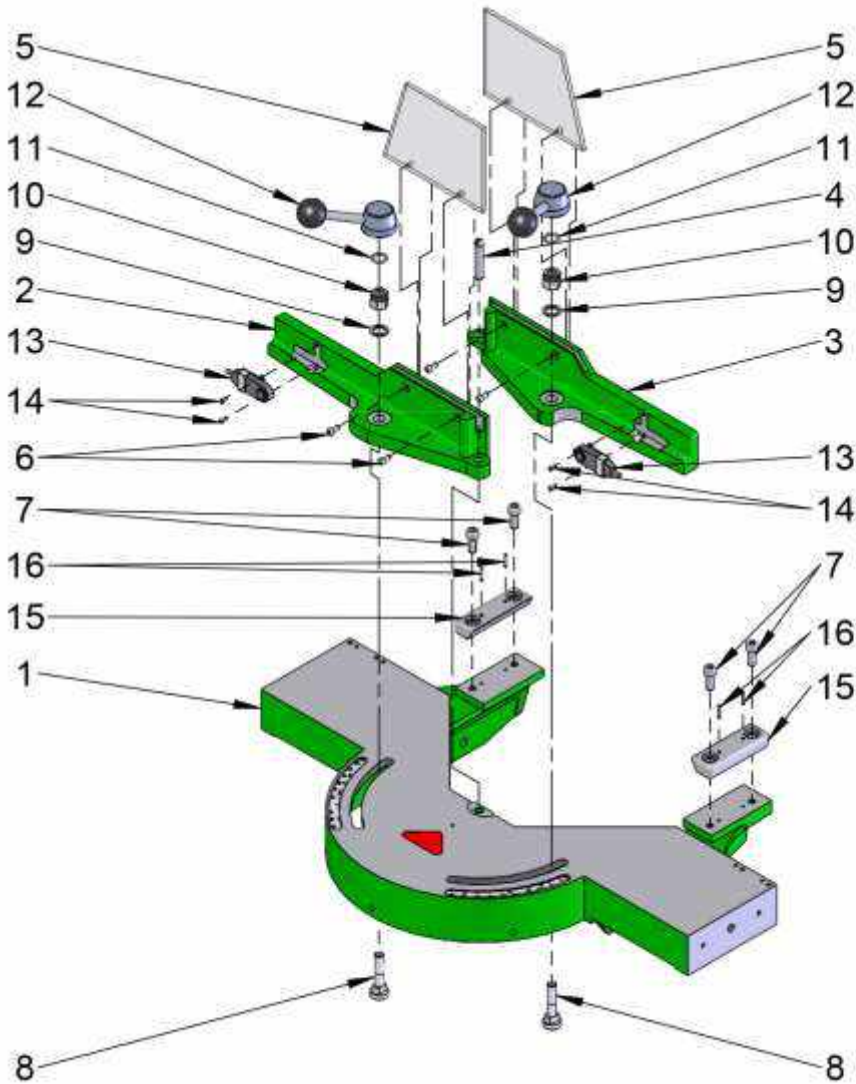
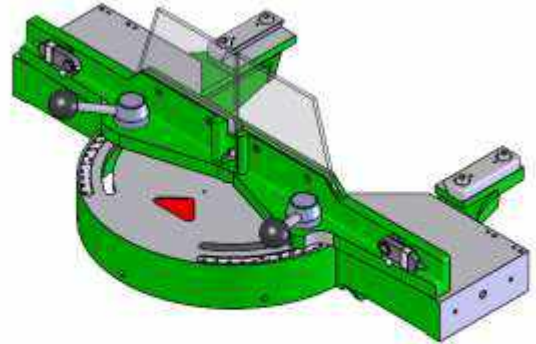



**00952100**  
**Bord - Table - Tisch**

Pos	Art.No.	Betegnelse	Designation	Benennung	Pcs
1	50000120	Bord EH	Table EH	Tisch EH	1
2	21300170V	Anslagsliste EH	Fence EH	Anschlagsleiste EH	1
3	21300170H	Anslagsliste EH	Fence EH	Anschlagsleiste EH	1
4	30000177	Styretap	Steering Pivot	Steuerzapfen	1
5	17600076	Plastikskærm	Safety Guard	Unfallschutz	2
6	50005010	Cylinderskrue M5x10	Socket Head Screw M5x10	Zylinderschraube M5x10	4
7	50008020	Cylinderskrue M5x20	Socket Head Screw M5x20	Zylinderschraube M5x20	4
8	80570071	Bolt for land	Bolt	Bolzen	2
9	40003112	Planskive FZV 12mm	Washer FZV 12mm	Scheibe FZV 12mm	2
10	80600073	Møtrik for Land (F+H+EH)	Hexagon Nut	Sechskantmutter	2
11	69131262	O-Ring	O-Ring	O-Ring	2
12	30000172	Håndtag, komplet	Hand Lever, complete	Handgriff, komplett	2
13	62083123	Microafbryger	Micro Switch	Mikroschalter	2
14	42003008	Kærvskrue m. cylindrisk hoved M3x6	Cheese Head Screw M3x6	Zylinderschraube M3x6	4
15	20000064	Styreliste, kort	Short Guide Rail	Kurze Steuerleiste	2
16	47003016	Spændestift	Clamping Pin	Spannstift	4

**WHEN ORDERING SPARE PARTS, PLEASE STATE SERIAL NUMBER OF THE MACHINE.**

**00952200**  
**Knivhoved frem/tilbage - Knife Block forward/backward -**  
**Messerkopf vorwärts/rückwärts**

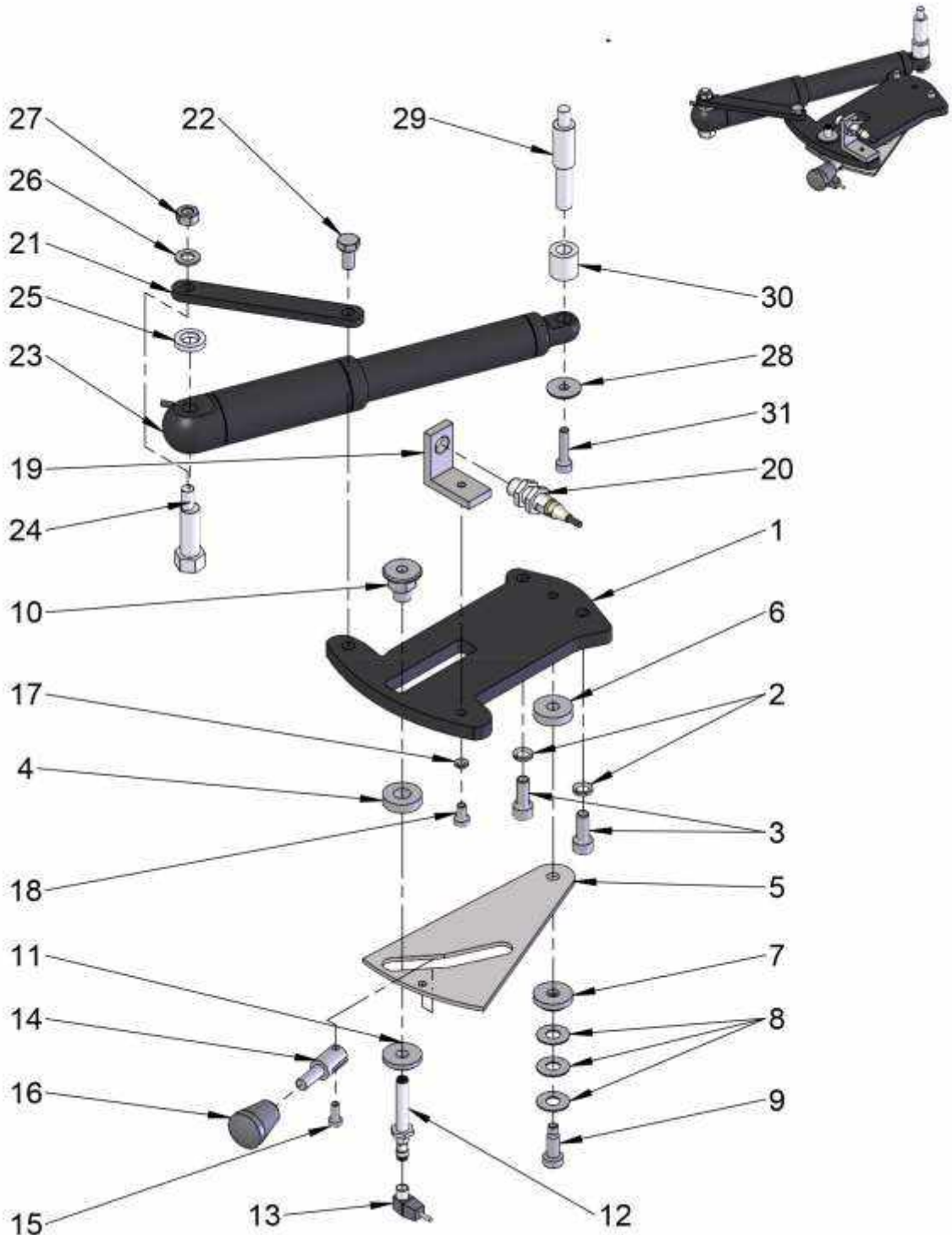

**00952200**
**Knivhoved frem/tilbage - Knife Block forward/backward –  
 Messerkopf vorwärts/rückwärts**

Pos	Art.No.	Betegnels	Designation	Benennung	Pcs
1	02001425	Cylinderplade	Cylinder Plate	Zylinderplatte	1
2	41000008	Fjederskive FZB 8mm	Spring Washer FZB 8mm	Federscheibe FZB 8mm	2
3	50008020	Cylinderskrue M8x20	Socket Head Screw M8x20	Zylinderschraube M8x20	2
4	02001433	Rulle	Guide	Steuer	1
5	02001427	Svingarm for cylinderplade	Swing Arm for Cylinder Plate	Schwenkarm für Zylinderplatte	1
6	02001437	Underlagsstykke	Washer	Unterlegsstück	1
7	02001439	Fjederhus	Spring Housing	Federgehäuse	1
8	40168209	Fjederskive	Spring Washer	Federscheibe	3
9	55060816	Pasbolt M6x8x16	Tloght Fitting Bolt M6x8x16	Passbolzen M6x8x16	1
10	02001431	Glider	Guide	Steuer	1
11	02001435	Underlagsskive	Bottom Part	Unterteil	1
12	62000253	Induktiv aftaster	Inductive Tracer	Näherungsiniator	1
13	62000248	Vinkelstik	Angle Plug	Winkelstecker	1
14	02001429	Håndtag	Hand Lever	Handhebel	1
15	50005012	Cylinderskrue M5x12	Socket Head Screw M5x12	Zylinderschraube M5x12	1
16	65300074	Greb	Handle	Handgriff	1
17	41000005	Fjederskive FZB 5mm	Spring Washer FZB 5mm	Federscheibe FZB 5mm	1
18	50006010	Cylinderskrue M6x10	Socket Head Screw M6x10	Zylinderschraube M6x10	1
19	02001420	Vinkel for føler	Angle Piece	Winkelstück	1
20	62000250	Induktiv aftaster	Inductive Tracer	Näherungsiniator	1
21	00950251	Beslag	Bracket	Beschlag	1
22	53008016	Sætskrue M8x16	Set Screw M8x16	Gewindestift M8x16	1
23	00950055	Aktuator CON35-400N 100 mm	Actuator CON35-400N 100 mm	Antriebe CON35-400N 100 mm	1
24	00950252	Excentrisk Bolt	Excentrically Bolt	Exzenterbolzen	1
25	00950253	Afstandsring Ø20.0x3.9	Distance Ring Ø20.0x3.9	Distanzring Ø20.0x3.9	1
26	40000008	Planskive FZB 8mm	Washer FZB 8 mm	Scheibe FZB 8 mm	1
27	43000008	Møtrik M8	Hexagon Nut M8	Sechskantmutter M8	1
28	00517	Skive	Washer	Scheibe	1
29	00950254	Aksel Ø13.9x75.0	Shaft Ø13.9x75.0	Welle Ø13.9x75.0	1
30	00950255	Bøsning Ø18.0x18.0	Bushing Ø18.0x18.0	Buchse Ø18.0x18.0	1
31	50006025	Cylinderskrue M6x25	Socket Head Screw M6x25	Zylinderschraube M6x25	1

**WHEN ORDERING SPARE PARTS, PLEASE STATE SERIAL NUMBER OF THE MACHINE.**

**00953000**

**Knivhoved, komplet - Knife Block Unit, complete – Messerkopf-Einheit, komplett**

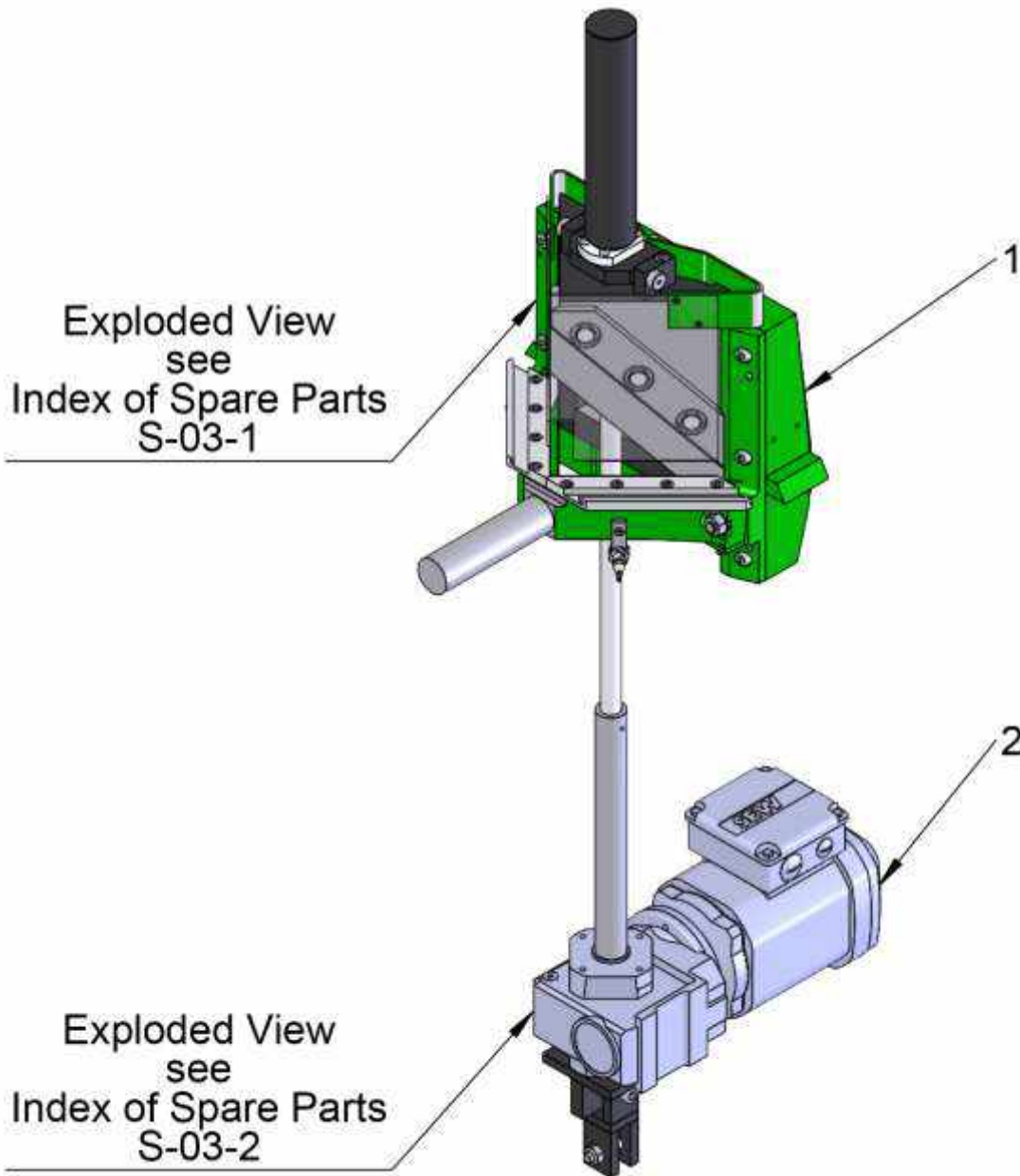

Pos	Art.No.	Betegnelse	Designation	Benennung
1	00953100	Knivhovedenhed	Knife Block Unit	Messerkopr-Einheit
2	00953200	Knivhoved, op/ned	Knife Block, up/down	Messerkopf herauf/herunter

**00953100**  
**Knivhovedenhet - Knife Block Unit - Messerkopf-Einheit**

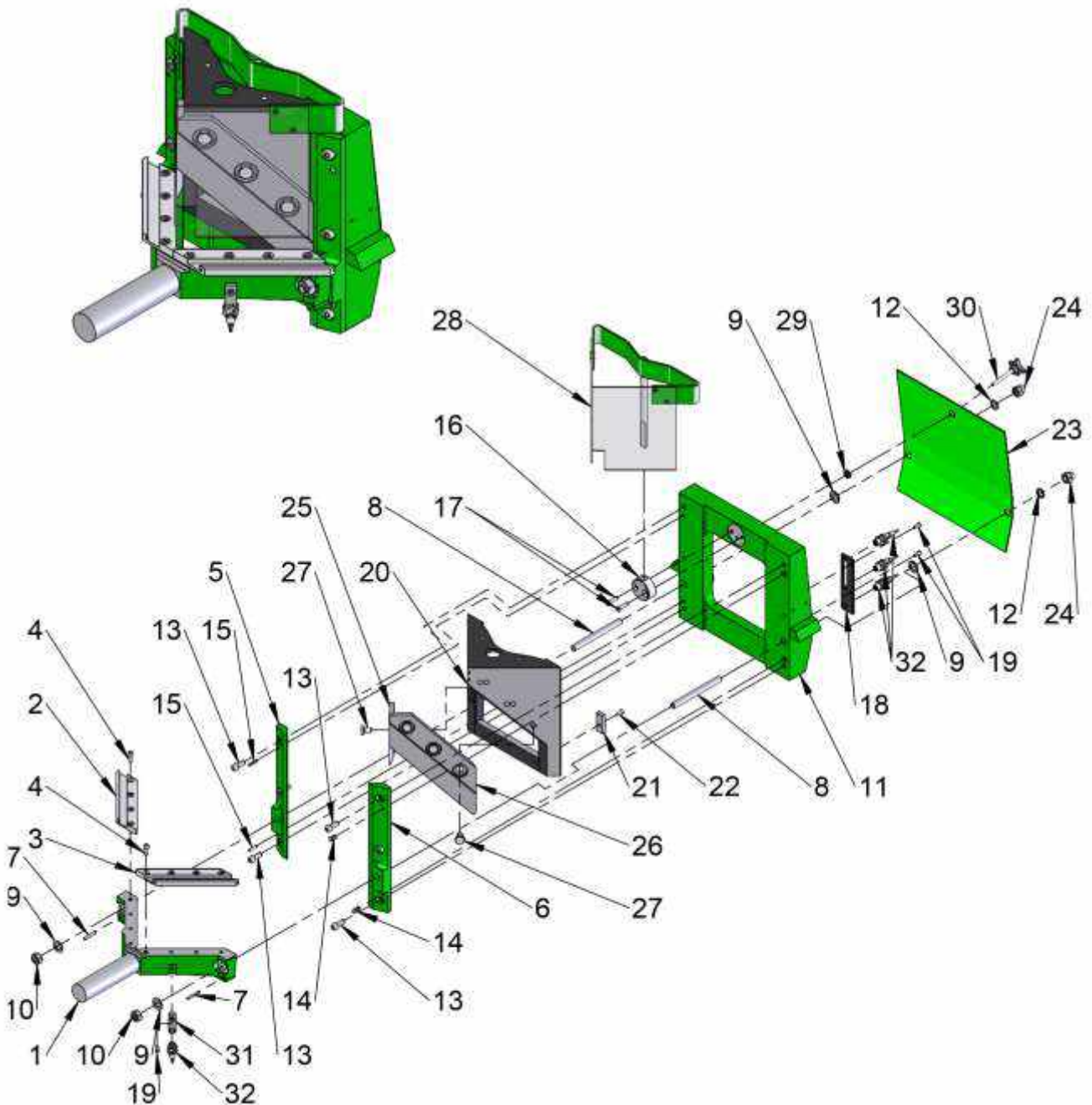

**00953100**
**Knivhovedenhed - Knife Block Unit - Messerkopf-Einheit**

Pos	Art.No.	Betegnelse	Designation	Benennung	Pcs
1	20000160	Kryds	Cross	Kreuzstück	1
2	14700302V	Underkniv f. F+H+EH	Bottom Knife f. F+H+EH	Untermesser f. F+H+EH	1
3	14700302H	Underkniv f. F+H+EH	Bottom Knife f. F+H+EH	Untermesser f. F+H+EH	1
4	50160304	Cylinderskrue M6x16	Socket Head Screw M6x16	Zylinderschraube M6x16	8
5	26500050V	Styreliste	Long Guide Rail	Lange Steuerleiste	1
6	26500050H	Styreliste	Long Guide Rail	Lange Steuerleiste	1
7	47005030	Spændestift	Clamping Pin	Spannstift	2
8	80820052	Pindbolt	Stud	Stiftschraube	2
9	40002112	Planskive FZV 12mm	Washer FZV 12mm	Scheibe FZV 12mm	4
10	43000012	Møtrik M12	Hexagon Nut M12	Sechskantmutter M12	2
11	20000130	Slæderamme	Slide Frame	Schlittenrahmen	1
12	40003112	Planskive FZV 12mm	Washer FZV 12mm	Scheibe FZV 12mm	2
13	50008020	Cylinderskrue M8x20	Socket Head Screw M8x20	Zylinderschraube M8x20	6
14	52008016	Pinolskrue M8x16	Center Screw M8x16	Zentrierschraube M8x16	2
15	47005020	Spændestift	Clamping Pin	Spannstift	2
16	17700077	Spændestykke f. skærm	Clamping Device f. Guard	Spannstück f. Schirm	1
17	49006025	Undersænket skrue M6x25	Countersunk Screw M6x25	Schraube, versenkt, M6x25	2
18	02092057	Beslag for føler	Fittings f. Sensor	Beschlag f. Sensor	1
19	50005012	Cylinderskrue M5x12	Socket Head Screw M5x12	Zylinderschraube M5x12	3
20	00950140	Knivhoved	Knife Block	Messerkopf	1
21	02122240	Højdestop f. knivhoved	Height Stop f. Knife Block	Oberer Anschlag f. Messerkopf	1
22	49005016	Undersænket skrue M5x16	Countersunk Screw M5x16	Schraube, versenkt, M5x16	1
23	02092060	Skærm	Shield	Schirm	1
24	43000112	Topmøtrik	Cap Nut	Hutmutter	2
25	30000301V	Kniv	Knife	Messer	1
26	30000301H	Kniv	Knife	Messer	1
27	80870303	Skrue f. kniv	Hexagon Screw f. Knife	Sechskantschraube f. Messer	6
28	17701079	Skærm, komplet (EH)	Safety Guard, complete (EH)	Schutzschirm, komplett (EH)	1
29	62006645	Gennemføring	Cabling	Kabeldurchführung	1
30	60785003	Håndhjul	Star Wheel	Sternrad	1
31	02122246	Beslag for bundstop	Bracket for Bottom Stop	Beschlag für unteren Anschlag	1
32	62000250	Induktiv Aftaster	Inductive Tracer	Näherungsinitiator	4

**WHEN ORDERING SPARE PARTS, PLEASE STATE SERIAL NUMBER OF THE MACHINE.**

**00953200**

**Knivhoved op/ned - Knife Block, up/down – Messerkopf, herauf/herunter**

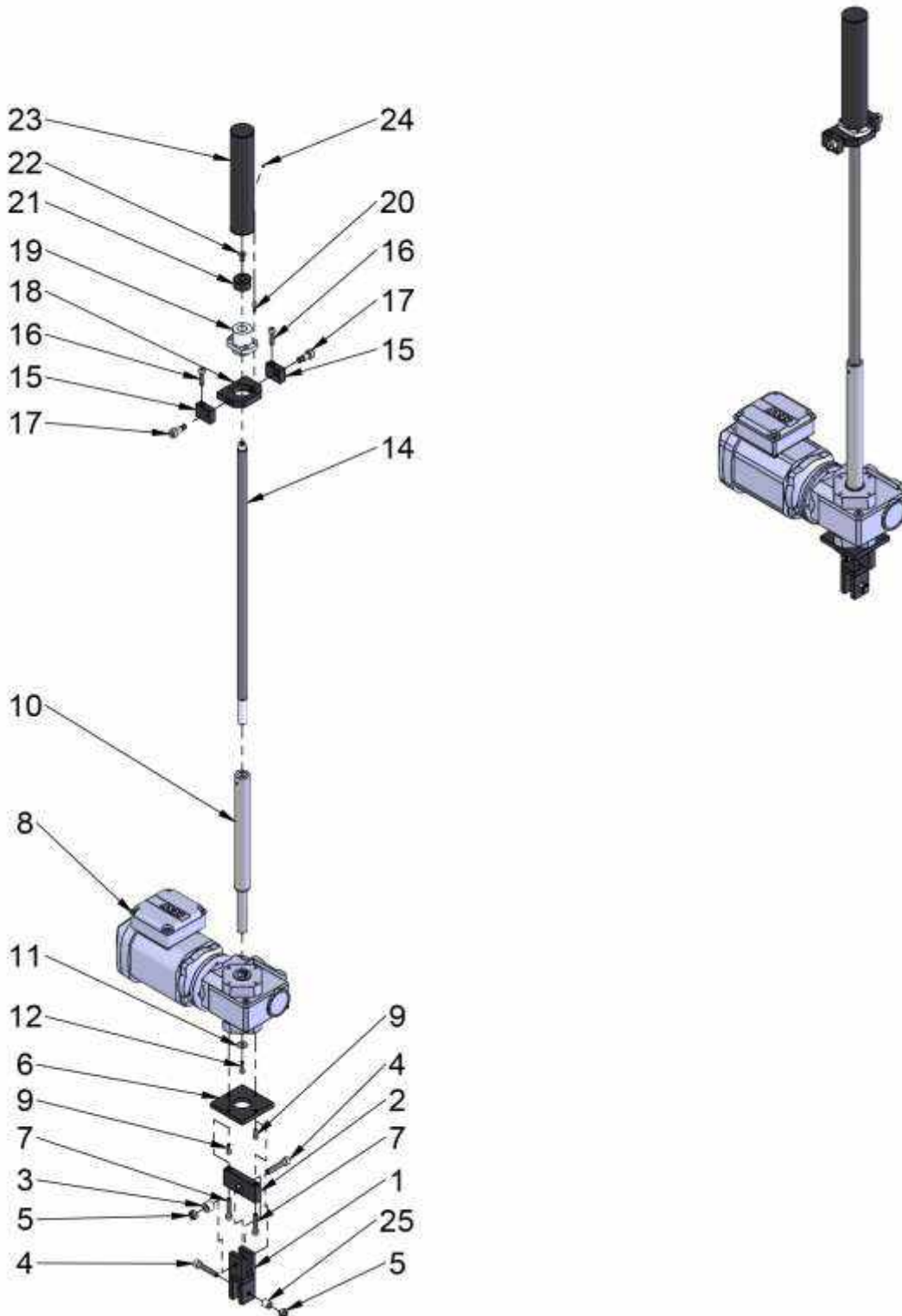

**00953200**
**Knivhoved op/ned - Knife Block, up/down – Messerkopf, herauf/herunter**

Pos	Art.No.	Betegnelse	Designation	Benennung	Pcs
1	00950101	Kryds	Cross	Kreutz	1
2	00950102	Beslag 40.0x15.0x90.0	Bracket 40.0x15.0x90.0	Beschlag 40.0x15.0x90.0	1
3	00950103	Bøsning Ø20.0x15.2	Bushing Ø20.0x15.2	Buchse Ø20.0x15.2	1
4	50010050	Cylinderskrue M10x50	Socket Head Screw M10x50	Zylinderschraube M10x50	2
5	44000100	Låsemøtrik M10	Lock Nut M10	Gegenmutter M10	2
6	00950104	Motorbeslag 90.0x10.0x90.0	Motor Bracket 90.0x10.0x90.0	Motorbeschlag 90.0x10.0x90.0	1
7	50008040	Cylinderskrue M8x40	Socket Head Screw M8x40	Zylinderschraube M8x40	2
8	00950105	SA37/T DRS71M4 Snekkegearmotor	SA37/T DRS71M4 Worm Gear Motor	SA37/T DRS71M4 Schneckengetriebe	1
9	50160304	Cylinderskrue M6x16	Socket Head Screw M6x16	Zylinderschraube M6x16	2
10	00950106	Aksel Ø30.0x380	Shaft Ø30.0x380	Welle Ø30.0x380	1
11	00517	Skive	Washer	Scheibe	1
12	50006020	Cylinderskrue M6x20	Socket Head Screw M6x20	Zylinderschraube M6x20	1
13	47004025	Rørstift	Pipe Pin	Rohrstift	1
14	00950107	Gevindspindel M20x680	Thread Spindle M20x680	Gewindespindel M20x680	1
15	00950108	Beslag 30.0x15.0x40.0	Bracket 30.0x15.0x40.0	Beschlag 30.0x15.0x40.0	2
16	50008030	Cylinderskrue M8x30	Socket Head Screw M8x30	Zylinderschraube M8x30	2
17	55101216	Pasbolt M10x12x16	Tight Fitting Bolt M10x12x16	Passbolzen M10x12x16	2
18	00950109	Plade 62.0x15.0x80.0	Plate 62.0x15.0x80.0	Platte 62.0x15.0x80.0	1
19	00950110	FSER2020 Kuglemøtrik	FSER2020 Ball Nut	FSER2020 Kugelmutter	1
20	50008016	Cylinderskrue M5x16	Socket Head Screw M5x16	Zylinderschraube M5x16	4
21	00950111	Bøsning Ø35.0x18.0	Bushing Ø35.0x18.0	Buchse Ø35.0x18.0	1
22	49008016	Undersænket skrue FZB M8x16	Countersunk Screw FZB M8x16	Schraube, versenkt FZB M8x16	1
23	00950112	Rør	Pipe	Rohr	1
24	51000505	Pinolskrue M5x5	Center Screw M5x5	Zentrierschraube M5x5	1
25	00950113	Bøsning Ø15.0x15.2	Bushing Ø15.0x15.2	Buchse Ø15.0x15.2	1

**WHEN ORDERING SPARE PARTS, PLEASE STATE SERIAL NUMBER OF THE MACHINE.**



**01400345**

**Falsstøtte komplet, V - Rebate Support, complete, L – Falzauflage, komplett, L**

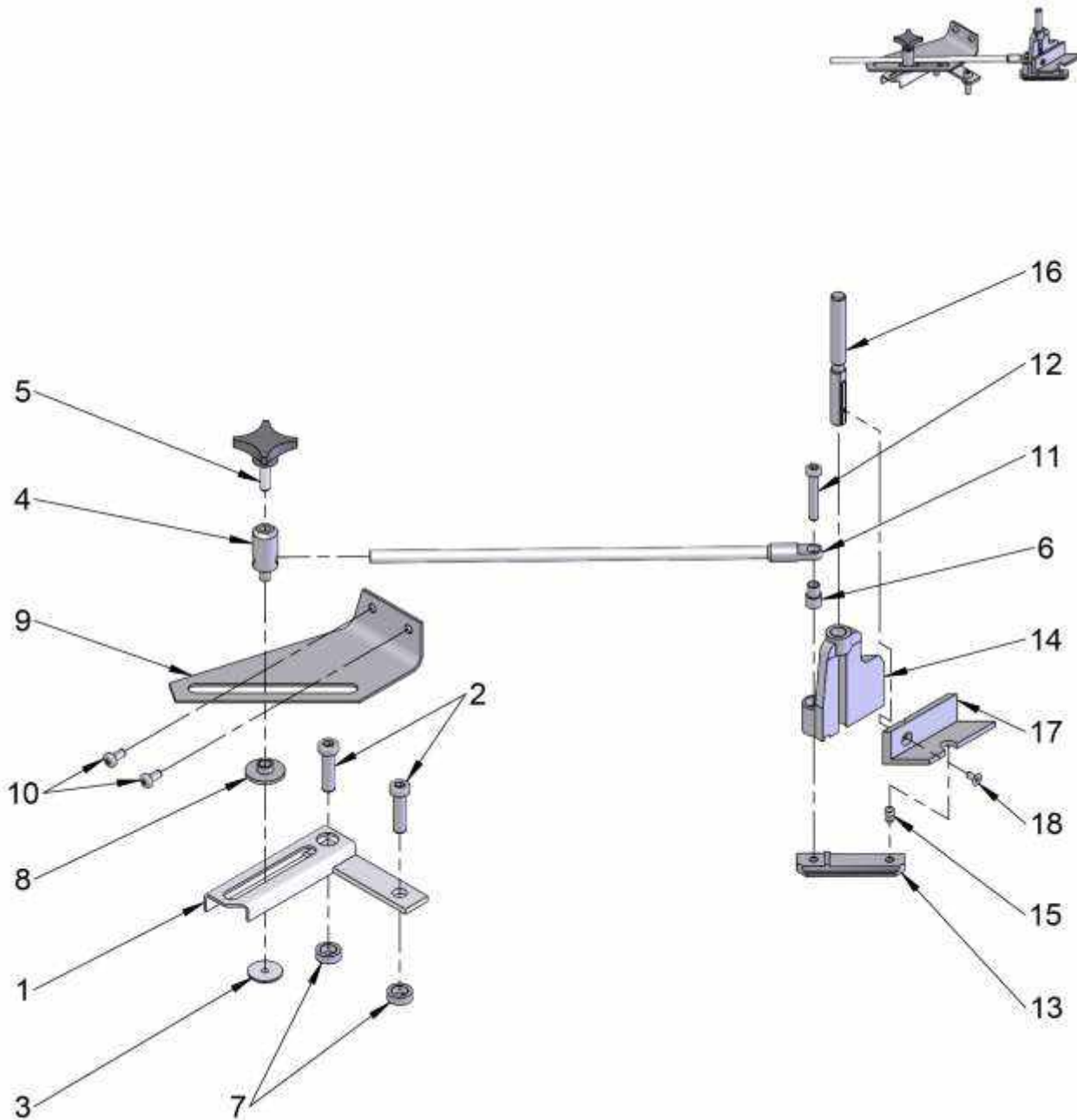

Rev. 2020.03.20

**01400345**
**Falsstøtte komplet, V - Rebate Support, complete, L – Falzauflage, komplett, L**

Pos	Art.No.	Betegnelse	Designation	Benennung	Pcs
1	05000121 V	Underpart	Bottom Part	Unterteil	1
2	50008030	Cylinderskrue FZ	Socket Head Screw FZ	Zylinderschraube FZ	2
3	05000125	Underlagsskive	Washer	Unterlegscheibe	1
4	05000123	Trækstangholder	Holder	Halter	1
5	60785007	Fingerskrue	Thumbscrew	Rändelschraube	1
6	05000127	Bøsning	Bushing	Buchse	1
7	05000126	Bøsning f. 8 mm skrue Fals. Aut.	Bushing f. 8 mm Screw Aut.Reb.	Buchse f. 8 mm Schraube Falz.Aut.	2
8	05000124	Glider	Slide Bar	Gleitstück	1
9	05000120V	Overplade	Top Plate	Oberplatte	1
10	49105008	Rundhovedet skrue M5x10	Round-head Screw M5x10	Rundkopfschraube M5x10	2
11	05000122	Trækstang	Draw Bar	Verbindungsstange	1
12	50006035	Cylinderskrue FZ	Socket Head Screw FZ	Zylinderschraube FZ	1
13	12203003V	Underpart	Bottom Part	Unterteil	1
14	21403403V	Holder	Holder	Halter	1
15	12300010	Tap (F+H+EH)	Pin (F+H+EH)	Zapfen (F+H+EH)	1
16	12503903	Tap f. falsstøtte	Pin f. Rebate Support	Zapfen f. Falzauflage	1
17	12203203V	Vinkeljern	Angle Iron	Winkelstahl	1
18	49004010	Undersænket skrue M4x8	Countersunk Screw M4x8	Schraube, versenkt, M4x8	1

**WHEN ORDERING SPARE PARTS, PLEASE STATE SERIAL NUMBER OF THE MACHINE.**

**01400345**

**Falsstøtte komplet, H - Rebate Support, complete, R – Falzauflage, komplett, R**

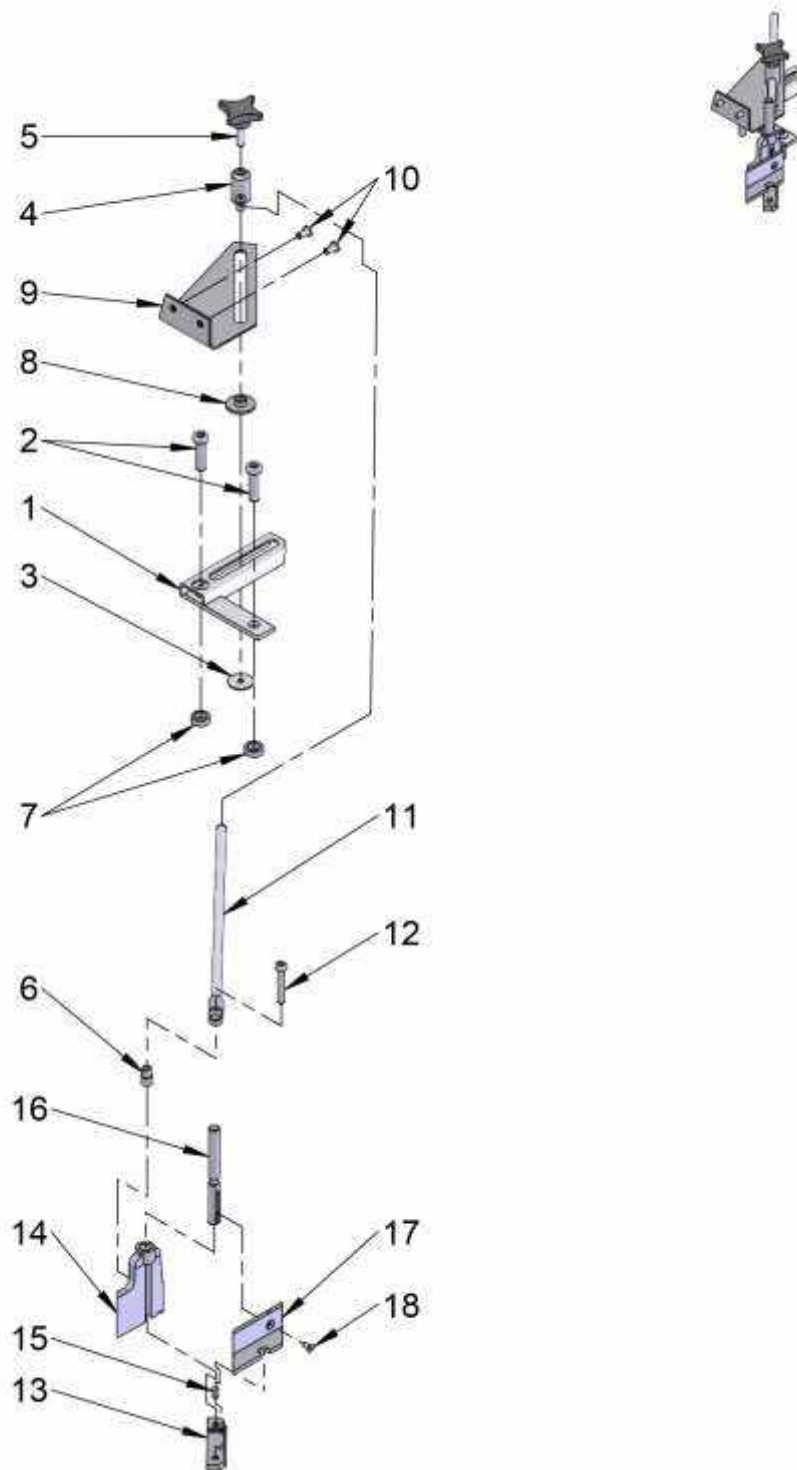

Rev. 2020.03.20

**01400345**
**Falsstøtte komplet, H - Rebate Support, complete, R – Falzauflage, komplett, R**

Pos	Art.No.	Betegnelse	Designation	Benennung	Pcs
1	05000121H	Underpart	Bottom Part	Unterteil	1
2	50008030	Cylinderskrue FZ	Socket Head Screw FZ	Zylinderschraube FZ	2
3	05000125	Underlagsskive	Washer	Unterlegscheibe	1
4	05000123	Trækstangholder	Holder	Halter	1
5	60785007	Fingerskrue	Thumbscrew	Rändelschraube	1
6	05000127	Bøsning	Bushing	Buchse	1
7	05000126	Bøsning f. 8 mm skrue Fals. Aut.	Bushing f. 8 mm Screw Aut.Reb.	Buchse f. 8 mm Schraube Falz.Aut.	2
8	05000124	Glider	Slide Bar	Gleitstück	1
9	05000120H	Overplade	Top Plate	Oberplatte	1
10	49105008	Rundhovedet skrue M5x10	Round-head Screw M5x10	Rundkopfschraube M5x10	2
11	05000122	Trækstang	Draw Bar	Verbindungsstange	1
12	50006035	Cylinderskrue FZ	Socket Head Screw FZ	Zylinderschraube FZ	1
13	12203003H	Underpart	Bottom Part	Unterteil	1
14	21403403H	Holder	Holder	Halter	1
15	12300010	Tap (F+H+EH)	Pin (F+H+EH)	Zapfen (F+H+EH)	1
16	12503903	Tap f. falsstøtte	Pin f. Rebate Support	Zapfen f. Falzauflage	1
17	12203203H	Vinkeljern	Angle Iron	Winkelstahl	1
18	49004010	Undersænket skrue M4x8	Countersunk Screw M4x8	Schraube, versenkt, M4x8	1

**WHEN ORDERING SPARE PARTS, PLEASE STATE SERIAL NUMBER OF THE MACHINE.**

**00953045**

**Listeholdere, komplet, V - Moulding Clamps, complete, L – Leistenhalter, komplett, L**

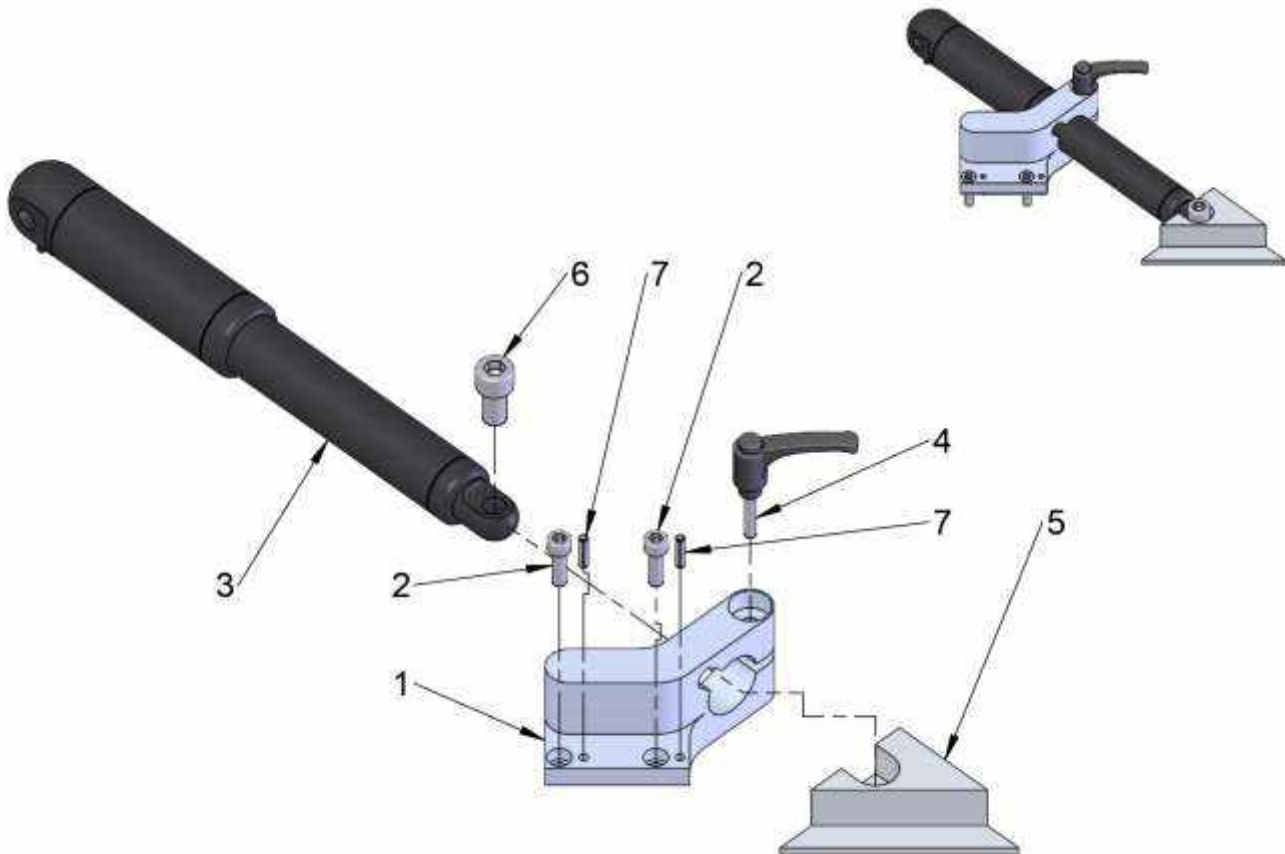

Pos	Art.No.	Betegnelsen	Designation	Benennung	Pcs
1	00950053V	Holder	Holder	Halter	1
2	50006020	Cylinderskrue M6x20	Socket Head Screw M6x20	Zylinderschraube M6x20	2
3	00950055	Aktuator CON35-400N 100 mm	Actuator CON35-400N 100 mm	Antriebe CON35-400N 100 mm	1
4	00950056	Kiphåndtag M5x25	Hand Lever M5x25	Handgriff M5x25	1
5	00950057V	Trykfod 70x25x70	Pressure Pad 70x25x70	Andrückstück 70x25x70	1
6	50010020	Cylinderskrue M10x20	Socket Head Screw M10x20	Zylinderschraube 10x20	1
7	47004016	Spændestift	Clamping Pin	Spannstift	2

**00953045**

**Listeholdere, komplet, H - Moulding Clamps, complete, R – Leistenhalter, komplett, R**

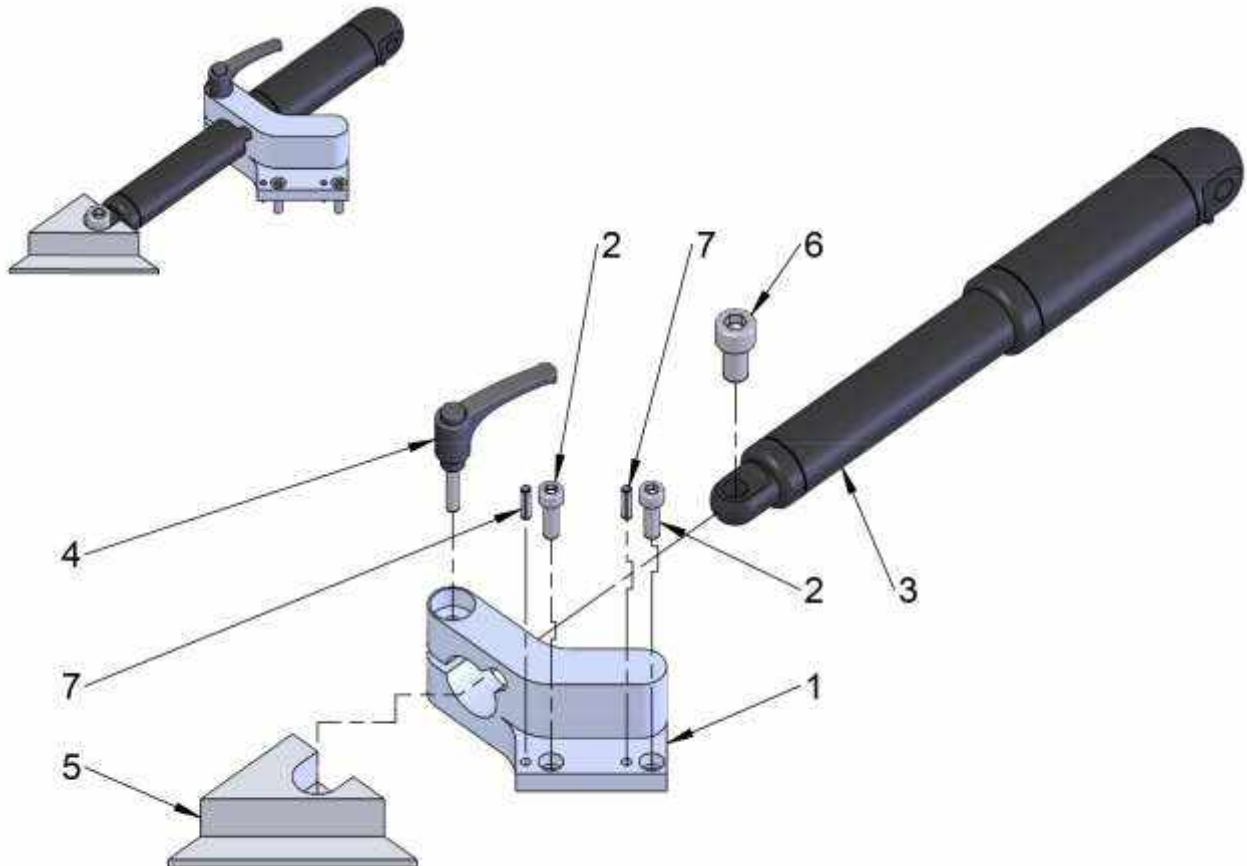

Pos	Art.No.	Betegnelse	Designation	Benennung	Pcs
1	00950053H	Holder	Holder	Halter	1
2	50006020	Cylinderskrue M6x20	Socket Head Screw M6x20	Zylinderschraube M6x20	2
3	00950055	Aktuator CON35-400N 100 mm	Actuator CON35-400N 100 mm	Antriebe CON35-400N 100 mm	1
4	00950056	Kiphåndtag M5x25	Hand Lever M5x25	Handgriff M5x25	1
5	00950057H	Trykfod 70x25x70	Pressure Pad 70x25x70	Andrücktstück 70x25x70	1
6	50010020	Cylinderskrue M10x20	Socket Head Screw M10x20	Zylinderschraube 10x20	1
7	47004016	Spændestift	Clamping Pin	Spannstift	2

**00954000**

**Bordforlænger, komplet – Table Extension, complete – Tischverlängerung, komplett**

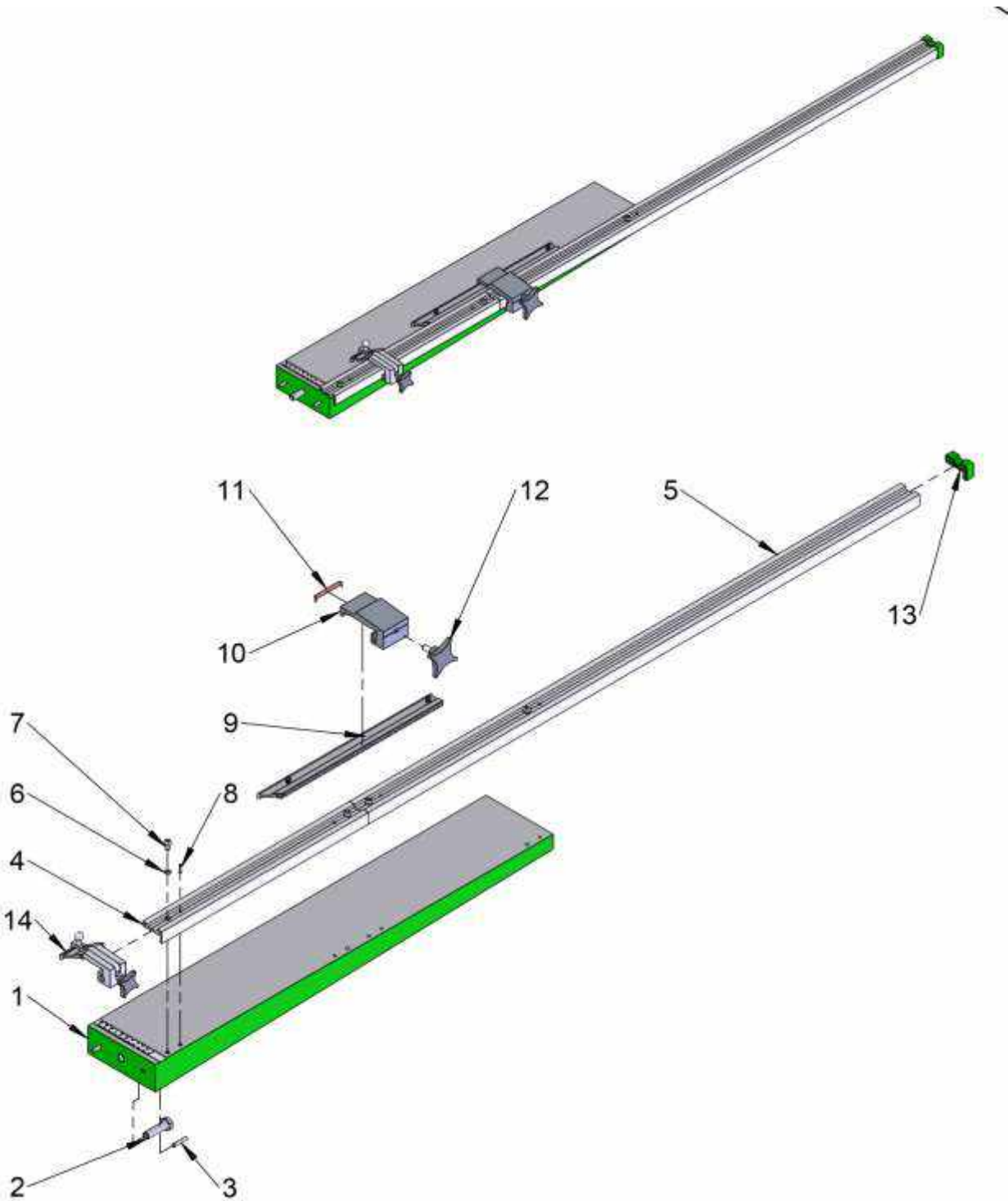

Rev. 2020.03.20

**00954000**
**Bordforlænger, komplet – Table Extension, complete – Tischverlängerung, komplett**

Pos	Art.No.	Betegnelse	Designation	Benennung	Pcs
1	20000061	Bordforlænger	Table Extension	Tischverlängerung	1
2	55716015	Stålbolt	Steel Bolt	Stahlbolzen	1
3	48005026	Konisk Kærvstift	Taper Pin	Kerbstift	2
4	74501012	Målskinne	Divided Beam	Meßschiene	1
5	74801010	Målskinne	Divided Beam	Meßschiene	1
6	40000006	Planskive FZB 6mm	Washer FZB 6mm	Scheibe FZB 6mm	4
7	50006010	Cylinderskrue M6x10	Socket Head Screw M6x10	Zylinderschraube M6x10	4
8	47004012	Spændestift	Clamping Pin	Spannstift	4
9	74001011	Stopskinne	Stop Beam	Anschlagsschiene	1
10	60785009	Stopklods	Stop Block	Endanschlag	1
11	67785007	Fjeder	Spring	Feder	1
12	60785008	Håndhjul	Star Wheel	Sternrad	1
13	74802013	Afdækning	Cover	Abdeckung	1
14	02220085	Specialstop EH	Second Stop EH	Zweiter ANschlag EH	1

**WHEN ORDERING SPARE PARTS, PLEASE STATE SERIAL NUMBER OF THE MACHINE.**



**Elektrisk udstyr - Electric Equipment - Elektrische Ausrüstung**

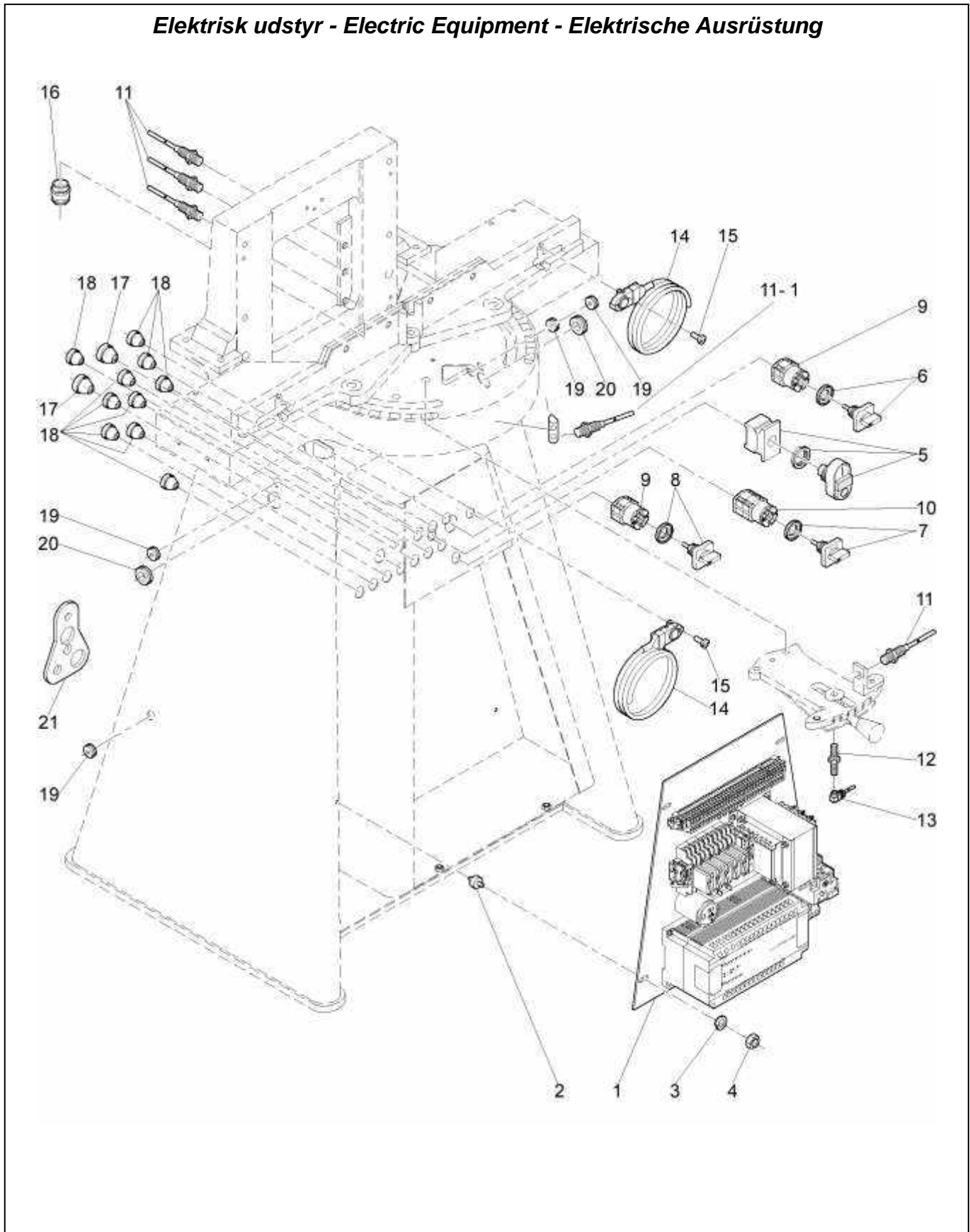

**Elektrisk udstyr - Electric Equipment - Elektrische Ausrüstung**

Pos	Art. No.	Betegnelse	Designation	Benennung
1	02610543	Styring kompl. komponenter se tavle 5-1	Control compl. parts look fig. 5-1	Steuerung kompl. Komponenten auf Tafel 5-1
2	62005000	Dæmper	Oscillation damper	Schwingungsdämpfer
3	41000005	Fjederskive	Spring washer	Federscheibe
4	43000005	Møtrik	Hexagon nut	Sechskantmutter
5	62000050	Start/Stop kontakt	Start/Stop switch	Start/Stopp Schalter
	62000058	Glødelampe (uden illustration)	Incandescent lamp (without illustration)	Glühlampe (ohne Abbildung)
6	62000051	Omskiftergreb 0-1 (Horisontal bevægelse, S-9 på el-diagram I-6-2)	Switch 0-1 (Horizontal movement, S-9 on EI-diagram I-6-2)	Umschalter 0-1 (Horisontal Bewegung, S-9 auf EI-Plan I-6-2)
7	62000052	Omskiftergreb 1-2-3 (Slaglængde, S-10 på el- diagram I-6-2)	Switch 1-2-3 (Length of stroke, S-10 on EI- diagram I-6-2)	Umschalter 1-2-3 (Hublänge, S-10 auf EI-Plan I-6-2)
8	62000053	Omskiftergreb ON-OFF (Listeholdere, S-8 på EI-diagram I-6-2)	Switch ON-OFF (Moulding clamps, S-8 on EI- diagram I-6-2)	Umschalter ON-OFF (Leistenhalter, S-8 auf EI-Plan I-6-2)
9	62000054	Omskifterkrop	Switch body	Schaltkörper
10	62000055	Omskifterkrop	Switch body	Schaltkörper
11	62000250	Induktiv aftaster	Inductive tracer	Näherungsinitiator
11-1	62000251-1	Induktiv aftaster m/beslag	Inductive tracer w/fittings	Näherungsinitiator m/Beschlag
12	62000253	Induktiv aftaster	Inductive tracer	Näherungsinitiator
13	62000248	Vinkelstik	Angle plug	Winkelstecker
14	62083123	Mikroafbryder	Mikro switch	Mikroschalter
15	42003008	Kærvskrue	Cylinder screw	Zylinderschraube
16	62003300	Kabelgennemføring	Cabling	Anschlußmuffe
17	62057710	Kabelgennemføring	Cabling	Kabeldurchführung
18	62057712	Kabelgennemføring	Cabling	Kabeldurchführung
19	62006650	Gennemføring	Cabling	Kabeldurchführung
20	62006662	Gennemføring	Cabling	Kabeldurchführung
21	62003280	Ledningsafkastning	Wire clip	Leitungsentlastung

**WHEN ORDERING SPARE PARTS, PLEASE STATE SERIAL NUMBER OF THE MACHINE.**

**Elektrisk udstyr - Electric Equipment - Elektrische Ausrüstung**  
**Styring - Control - Steuerung**

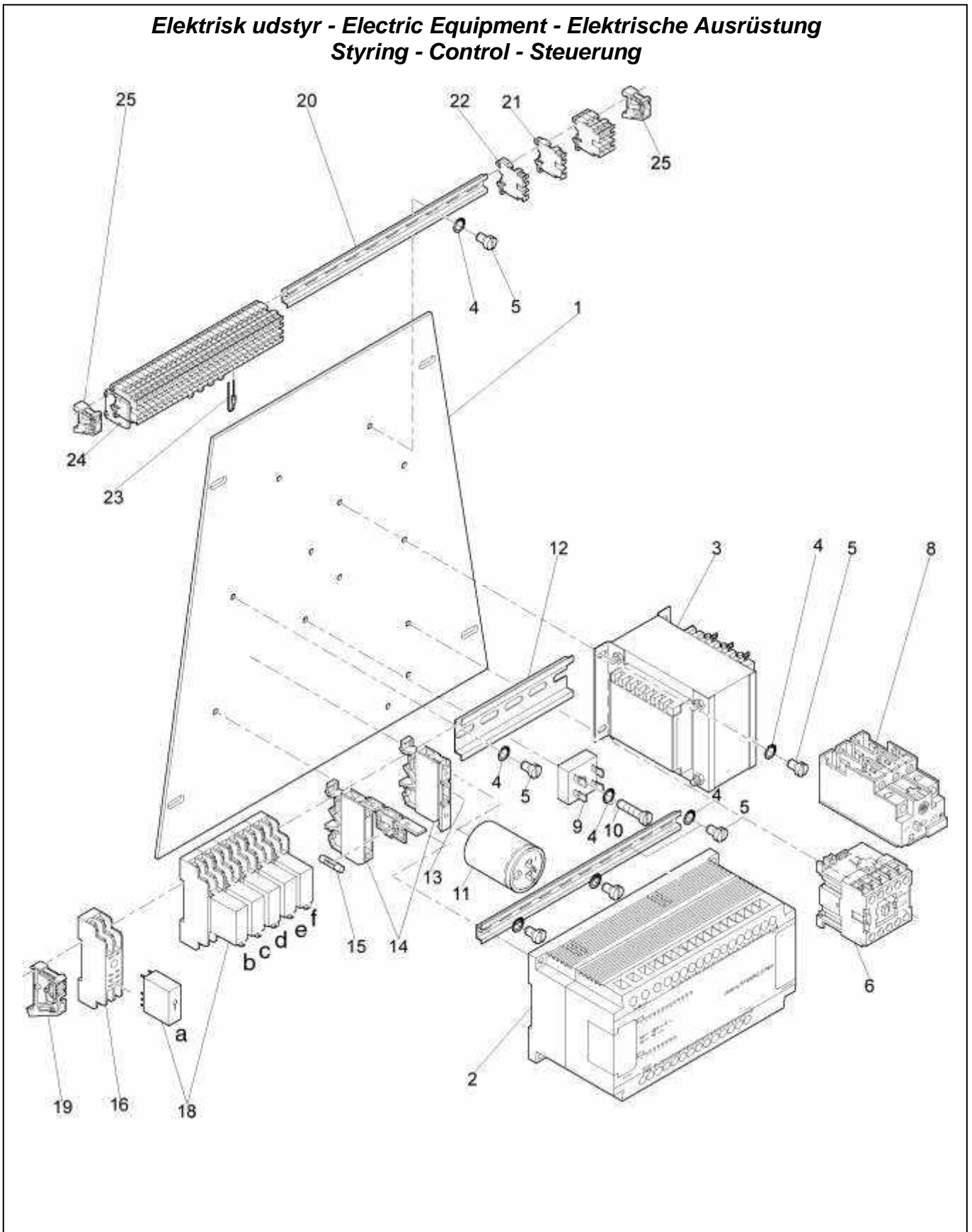

**Elektrisk udstyr - Electric Equipment - Elektrische Ausrüstung**  
**Styring - Control - Steuerung**

Pos	Art. No.	Betegnelse	Designation	Benennung
1	02000405	Monteringsplade	Mounting plate	Montageplatte
2	80001110	Styring OMRON	Control OMRON	Steuerung OMRON
3	80001115	Nettransformer	Transformer	Netztransformator
4	41000000	Låsering	Locking ring	Zahnscheibe
5	42003025	Kærviskrue	Cylinder screw	Zylinderschraube
6	80001222	Startrelæ	Starter	Startrelais
7				
8	80001226	Termorelæ	Thermo relay	Thermorelais
9	80001135	Ensretter	Rectifier	Gleichrichter
10	42003030	Kærviskrue	Cylinder screw	Zylinderschraube
11	80001240	Kondensator	Condensator	Kondensator
12	80001150	Skinne	Rail	Schiene
13	80001195	Endeplade	End plate	Endplatte
14	80001190	Sikringsklemme	Fuse terminal	Sicherungsklemme
15	80001215	Finsikring	Fine fuse	Feinsicherung
16	80001126	Sokkel f. printrelæ	Base for control relay	Socket f. Steuerrelais
17				
18	80001121	Relæ	Relay	Relais
19	80001200	Endevinkel	Stop angle	Endwinkel
20	80001150	Skinne	Rail	Schiene
21	80001156	Gennemgangsklemme	Forward terminal	Durchgangsklemme
22	80001186	Jordklemme	Earthing terminal	Erdklemme
23	80001130	Diode	Diode	Diode
24	80001161	Endeplade	End plate	Endplatte
25	80001200	Endevinkel	Stop angle	Endwinkel

**WHEN ORDERING SPARE PARTS, PLEASE STATE SERIAL NUMBER OF THE MACHINE.**

The relays No.18 a to f control:

- a: By-pass valve
- b: Knife block forwards
- c: Knife block backwards
- d: Knife block down
- e: Knife block up
- f: Moulding clamps



**El-skema - Electric Diagram – El-Schaltplan**

0	1	2	3	4	5	6	7	8	9
PRODUCED BY: <b>INDUMATIC</b>									
<b>GENERAL SERVICES CONSTRUCTION SERVICES</b>									
ALL constructions and component choice are made in accordance with EN 60 204-1									
THIS component must be incorporated in the machine type: DANLIST ELLISTEKLIPPER									
<b>BYGGE ÅR</b> YEAR OF MANUFACTURE ANNÉE DE FABRICATION		05. 2016							
<b>KOMMISSION NO.</b> COMMISSION NO. NO. DE COMMISSION		Z50516							
<b>KONSTRUKTION FORUDSETNINGER</b> LC: KR LC: MIN		10 KR 0 KR							
<b>TEGNINGSNUMMER</b> DRAWING NO. N° DE DESSIN		Z50516							
<b>DRIFTSPÆNDING</b> SERVICE VOLTAGE TENSION DE SERVICE		3 x 400/230		V					
<b>FREKVEN</b> FREQUENCY FRÉQUENCE		50		Hz					
<b>NOMINEL STRØM</b> NOMINAL CURRENT COURANT NOMINALE		10		A					
<b>STYRESPÆNDING</b> CONTROL VOLTAGE COMMANDÉ ÉLECTRIQUE		24		VDC					
<b>ADRESSE</b> ADDRESS ADRESSE		Indumatic: allestevadsvej 24 DK 8900 Randers Tel: +45 8643 5155							
<b>PROJEKT STARTED</b> LAST MODIFIED P-INTAGE Designer			<b>ELEKTRISK LISTEKLIPPER</b> STANDARD			<b>INDUMATIC A/S</b> allestevadsvej 24 DK 8900 Randers 0045 8643 5155			<b>GENERELLE KONSTRUKTIONSDOKUMENTATIONER</b>
24 Jun 2016 06 Mar 2017 24 Mar 2018 JH						FOOTPRINT: Z50516			PREV: 200 NEXT: 400 PAGE: 201

**El-skema - Electric Diagram – El-Schaltplan**

PLC TYPE: OMRON CPM1 30		KORT TYPE: -		SLOT NO: MASTER		WORD: -	
OMRON INPUT LIST		PART: 1 OFF 1					
TERM- NRL NO	I/O NO	LABEL	COMMENT	EQUIPMENT	PREV	201	REV
00	00.00	-S0.00	Z HÅNSTRYK VENSTRE SIDE	350518			402
01	00.01	-S0.01	Z HÅNSTRYK HØJRE SIDE				
02	00.02	-B0.02	2MM FØLER				
03	00.03	-B0.03	KLIPPENØVED I POS BUND				
04	00.04	-B0.04	KLIPPENØVED I POS TØP - NEDERSTE POSITION				
05	00.05	-B0.05	KLIPPENØVED I POS TØP - MIDTER POSITION				
06	00.06	-B0.06	KLIPPENØVED I POS TØP - ØVERSTE POSITION				
07	00.07	-B0.07	HORIZONTAL STOP				
08	00.08	-S0.08	OMSKIFTER VALG AF SLÅGLENGDE				
09	00.09	-S0.09	OMSKIFTER VALG AF SLÅGLENGDE				
10	00.10	-S0.10	OMSKIFTER VALG HORIZONTAL STOP ON/OFF				
11	00.11	-S0.11	OMSKIFTER VALG SPANDEFUNKTION ON/OFF				
				I/O LISTE			
				INDUMATIC A/S			
				21 Elvadrøvej 24			
				DK 8900 Randers			
				DD55 86437025			
Project started	14 Jun 2010	ELEKTRISK LISTEKLEPPER					
List modified	14 Jun 2010	STRØMARI					
P-Include	24 Mar 2018						
Designer	JH						





**El-skema - Electric Diagram – El-Schaltplan**

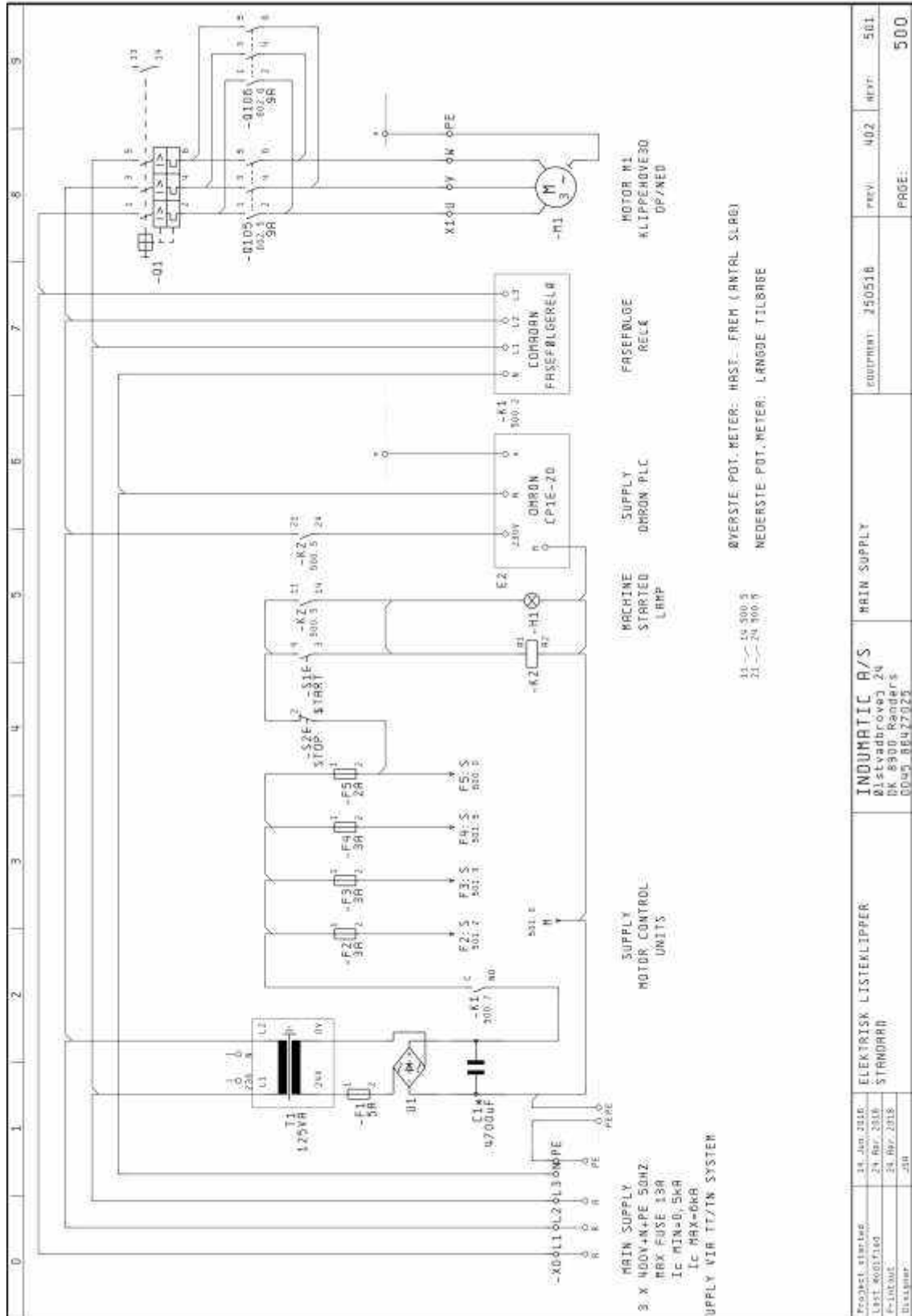

**El-skema - Electric Diagram – EI-Schaltplan**

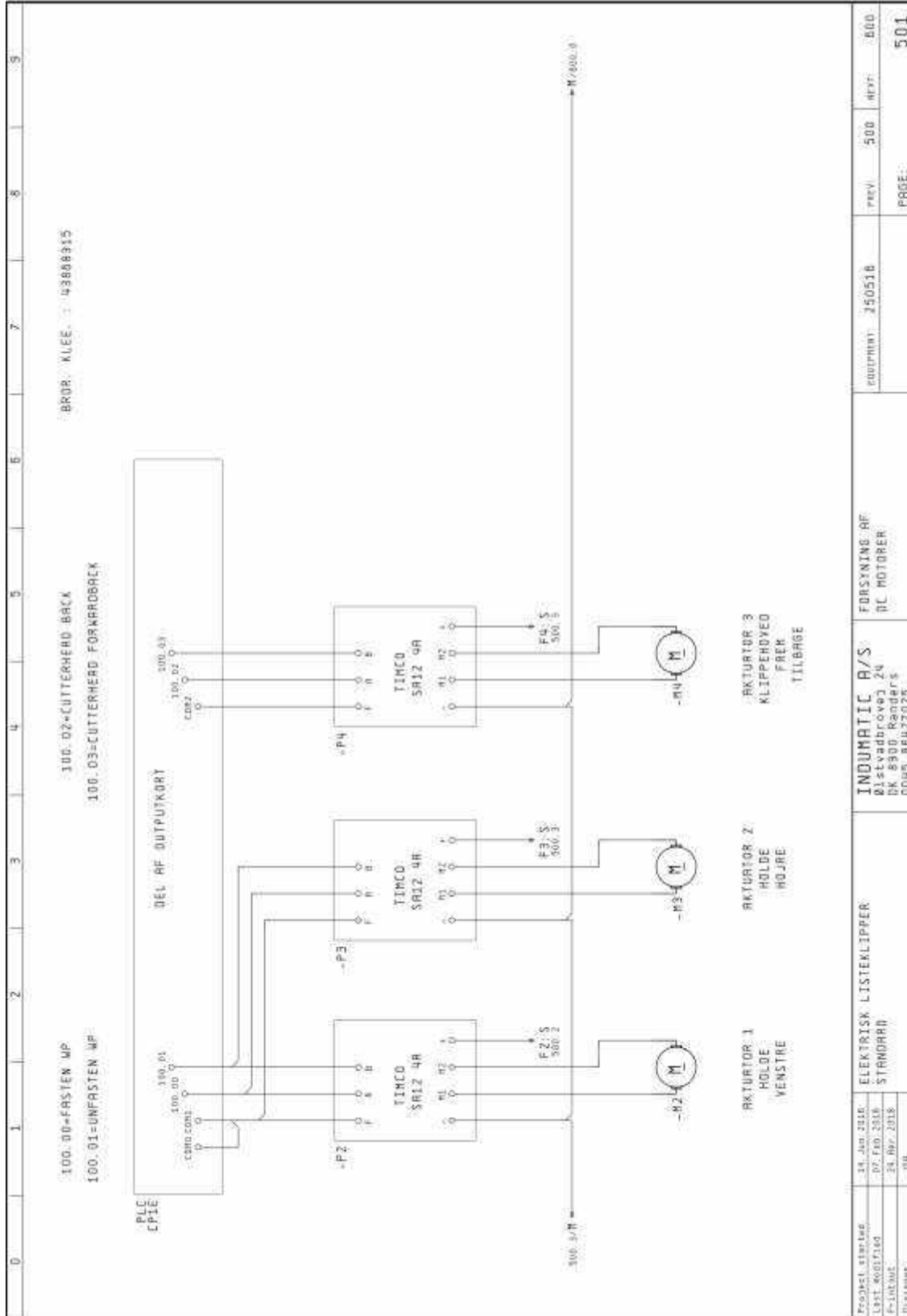

**El-skema - Electric Diagram – El-Schaltplan**

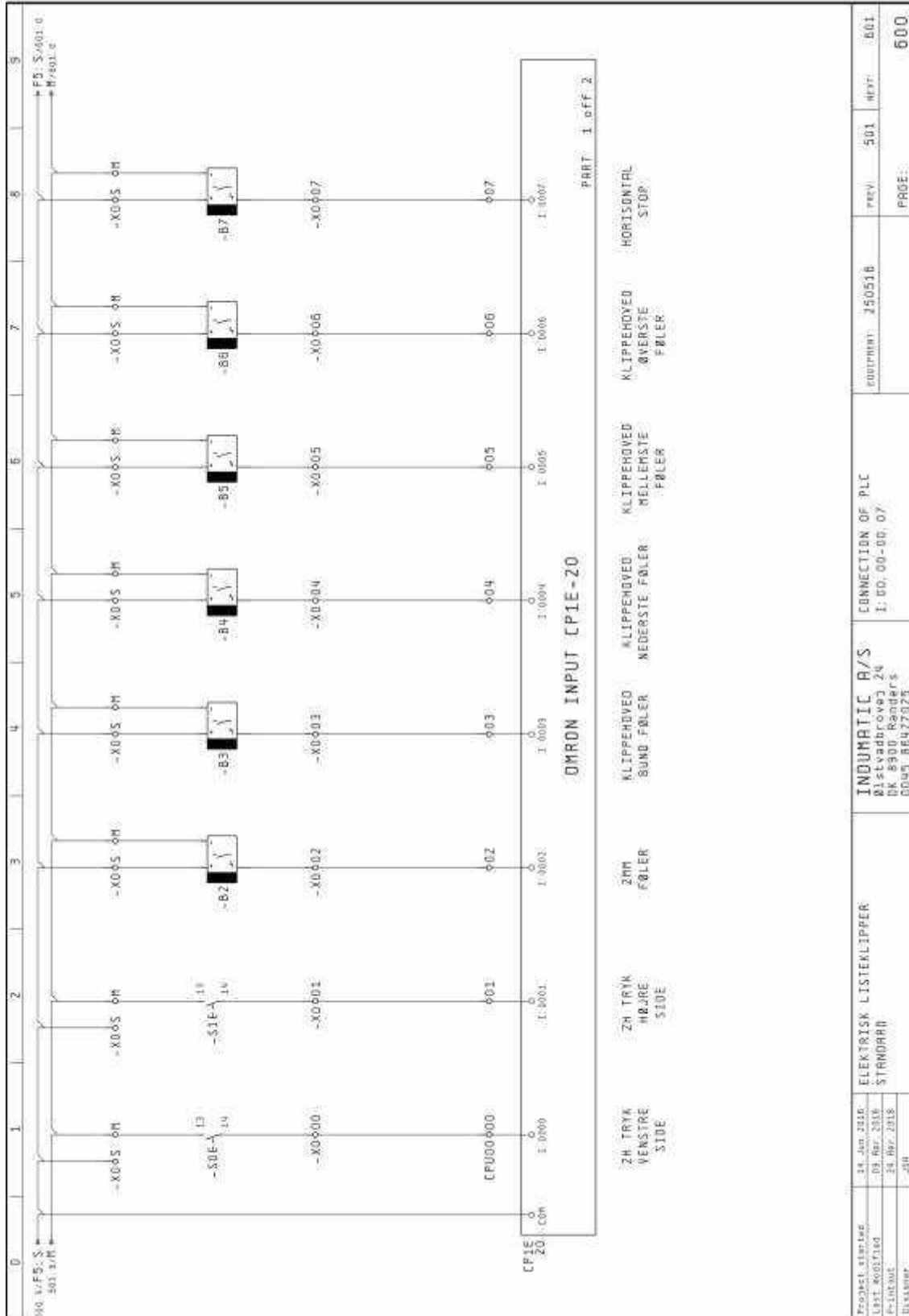

**El-skema - Electric Diagram – El-Schaltplan**

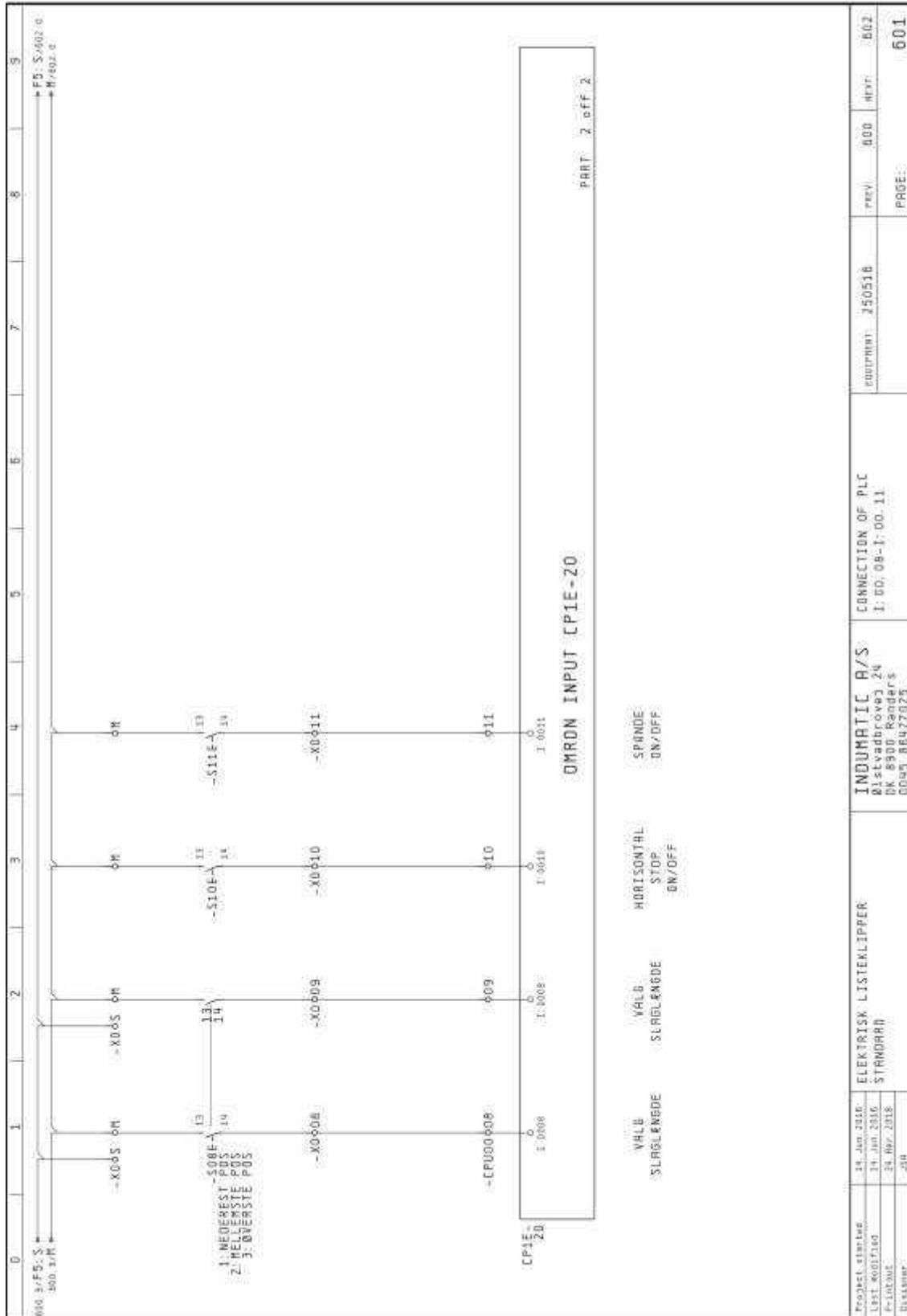

**El-skema - Electric Diagram – El-Schaltplan**

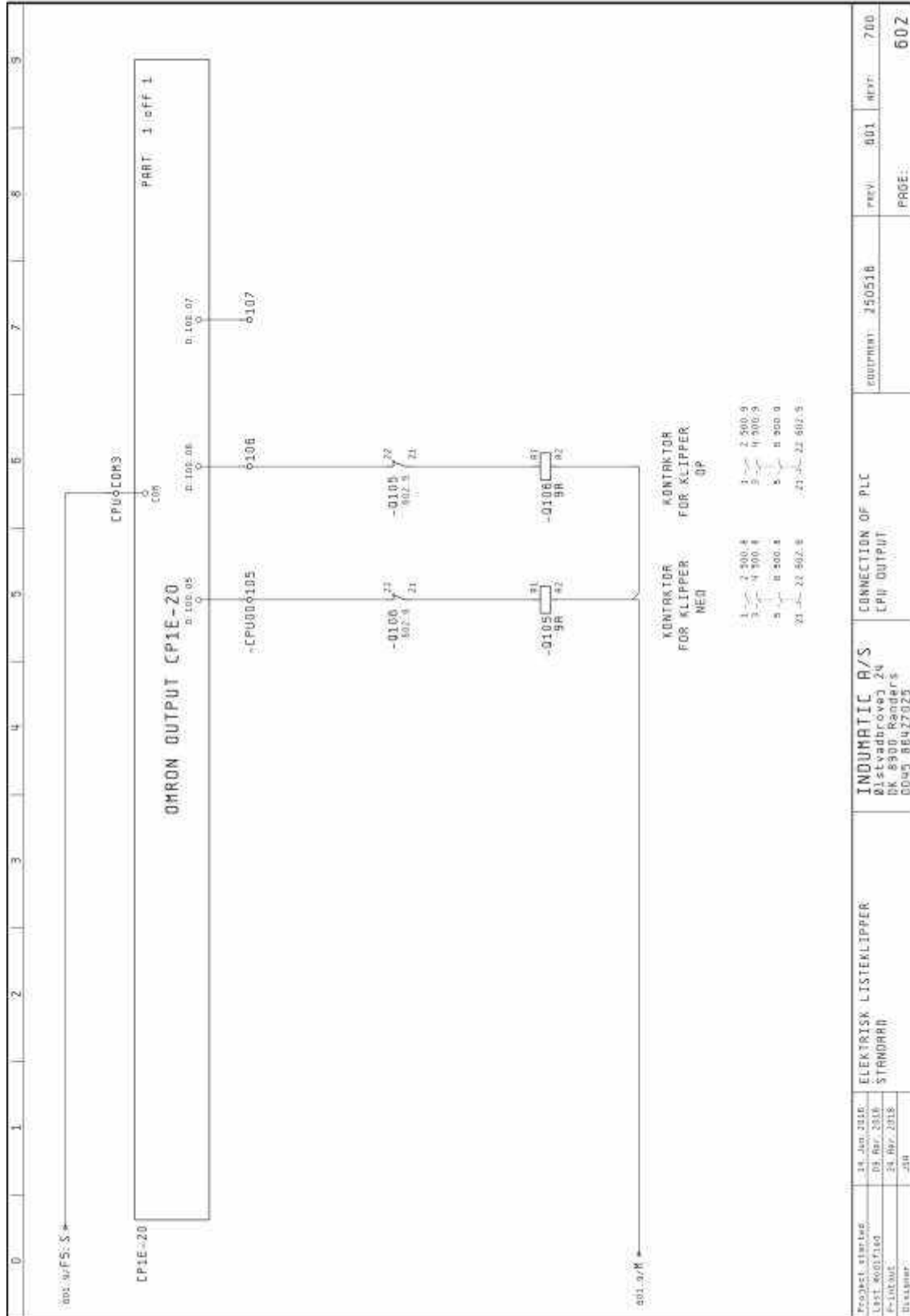

Dan-List A/S  
 Haraldsvej 21 - DK-8960 Randers - Denmark  
 Phone: +45 8643 5155 - Fax: +45 8643 5100  
 E-mail: danlist@danlist.dk  
 www.danlist.dk - www.danlistvideos.com

**Index of Spare Parts EL-01-11**
**El-skema - Electric Diagram – El-Schaltplan**

TERMINAL STRIP/CONNECTOR DESIGNATION: -X0									
0	1	2	3	4	5	6	7	8	9
COMMENTS	FROM DESTINATION	TERMINAL / IN/OUT	TERMINAL NUMBER	TO DESTINATION	TERMINAL / IN/OUT	TERMINAL NUMBER	TO DESTINATION	TERMINAL / IN/OUT	PAGE/ PATH
SIGNAL FOR KLIPPER ØP	-X0	M		-B1				SE	802.6
ZH TRYK VESTRE SIDE	-S0	13		-P4				1	600.1
ZH TRYK HØJRE SIDE	-S1	13							600.2
ZMM FØLER	-B2								600.3
KLIPPEDVED BUND FØLER	-B3								600.4
KLIPPEDVED NEDERSTE FØLER	-B4								600.5
KLIPPEDVED MELLESTE FØLER	-B5								600.6
KLIPPEDVED ØVERSTE FØLER	-B6								600.7
HORISONTAL STOP	-B7								600.8
VALG SLABLANGDE	-S08	13							601.1
VALG SLABLANGDE	1314								601.2
HORISONTAL STOP ON/OFF	-S10	13							601.3
SPANDE ON/OFF	-S11	13							601.4
RAIN SUPPLY 3 X 400V+N+PE 50HZ	M8X-6XA SUPPLY VIA T1/TN SWITSEN								500.1
									601.1
									600.1
ZH TRYK VESTRE SIDE	-B2			CP1E20				COM	600.2
ZMM FØLER	-B3								600.3
KLIPPEDVED BUND FØLER	-B4								600.4
KLIPPEDVED NEDERSTE FØLER	-B5								600.5
KLIPPEDVED MELLESTE FØLER	-B6								600.6
KLIPPEDVED ØVERSTE FØLER	-B7								600.7
HORISONTAL STOP									600.8
VALG SLABLANGDE	CP00	00		CFU				COM3	601.2
ZH TRYK VESTRE SIDE	CP00	01		-S0				14	600.1
ZH TRYK HØJRE SIDE	CP00	02		-S1				14	600.2
ZMM FØLER	CP00	03		-B2					600.3
KLIPPEDVED BUND FØLER	CP00	04		-B3					600.4
KLIPPEDVED NEDERSTE FØLER	CP00	05		-B4					600.5
KLIPPEDVED MELLESTE FØLER	CP00	06		-B5					600.6
KLIPPEDVED ØVERSTE FØLER	CP00	07		-B6					600.7
HORISONTAL STOP	CP00	07		-B7					600.8

PROJECT STARTED	24. Jun 2010	ELEKTRISK LISTEKLIPPER	-X0	EQUIPMENT	250516	PREV	902	REF1	701
LAST MODIFIED	14. Jun 2016	INDUMATIC A/S							
FILENAME	24. Apr 2018	Østvadbrovej 24							
Designer	JH	DK 8900 Randers							
		0045_86437025							700



**El-skema - Electric Diagram – El-Schaltplan**

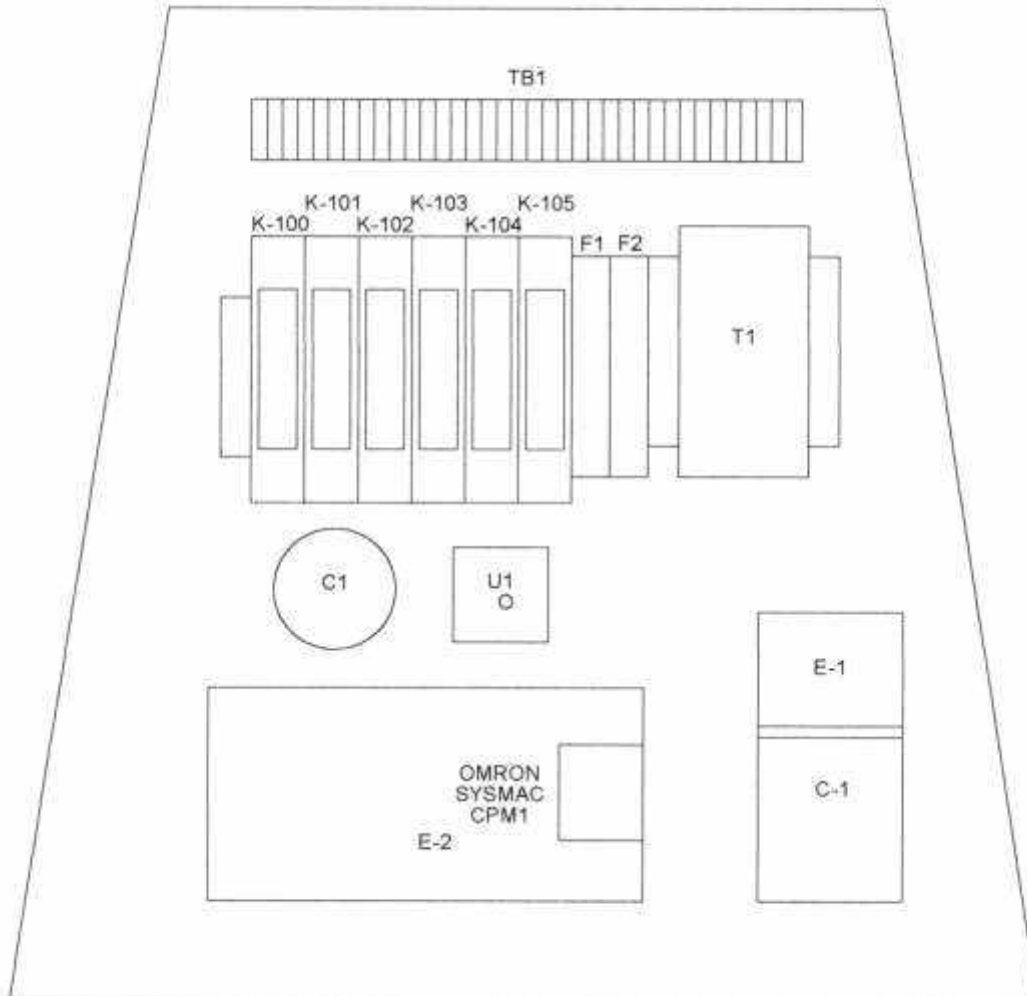

**PART LIST**

Pos. No.	Description	Type
E-2	OMRON SYSMAC CPM 1 PLC	CPM1-20CDR
T1	ST 100 4007230/24 V Transformer	TD 3000-2
C-1	CA4-10 240 V Contractor	J7K-BM-10
E-1	Overloads	
K100/105	G2R-1-SN Relay 24.0 VDC	1P.10A LED
K100/105	OMRON Relay socket 2 pol	P2RF-05-E
F1/F2	5A Fuse	5A
TB1	2.5 mm <sup>2</sup> Terminalstrib	
C1	Condensator 2200 UF 63V	
U1	BROKOBL	2506 600V/25A
S-10/S-11/S0-S1	MULTI.M/L 800 EP	LU2B213 DL C
B2-B4	Proximity Switch	E2EG-X2CI
S8	Toggle Switch ON-OFF LFC-A-3-175	LC1-10-1751

**WHEN ORDERING SPARE PARTS, PLEASE STATE SERIAL**